

DIM.	TOL.
5mm DOWN	±0.2
5~20mm	±0.3
20~40mm	±0.4
40~60mm	±0.5
60~100mm	±0.8
100mm UP	±1.0

REVISIONS			
REV	DESCRIPTION	DATE	BY

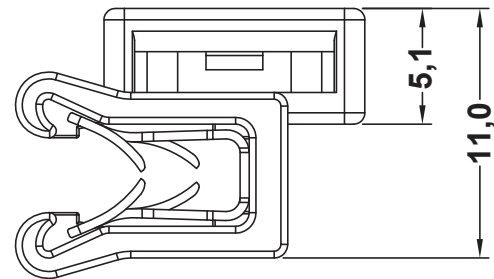
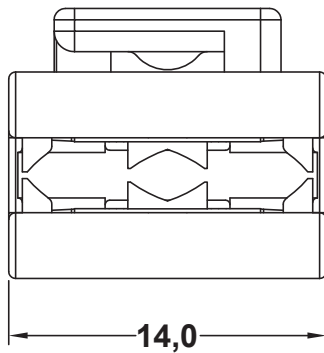
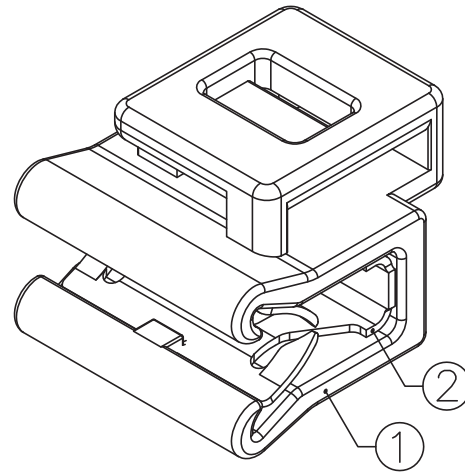
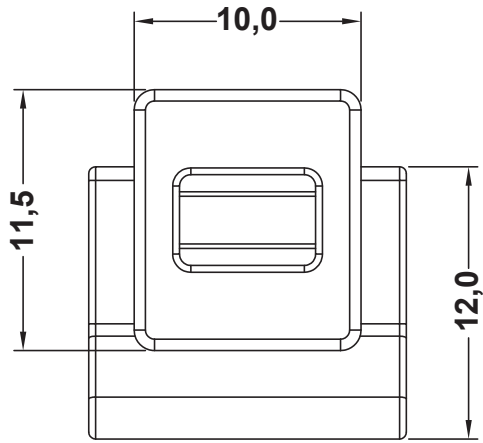

RECOMMEND SUITABLE FOR THICKNESS: 1.5~2.0mm

P/N.	NAME	MATERIAL	COLOR
①	CABLE TIES MOUNT BODY	NYLON 66 UL94V-2	BLACK
②	CABLE TIES MOUNT METAL PLATE	SUS	-



TITLE		CABLE TIES MOUNT	
MATERIAL		SEE ABOVE	DATE 15/09/2015
			DRAWN S.P.
PART NUMBER 10961AA01GS		DRAWING NUMBER 15.09.15.10961.0.E	COLOR SEE ABOVE
SIZE A4	SCALE 3:1	UNIT mm	REV A
		UNLESS OTHERWISE SPECIFIED TOLERANCE SEE ABOVE	CHECK APPROVED