

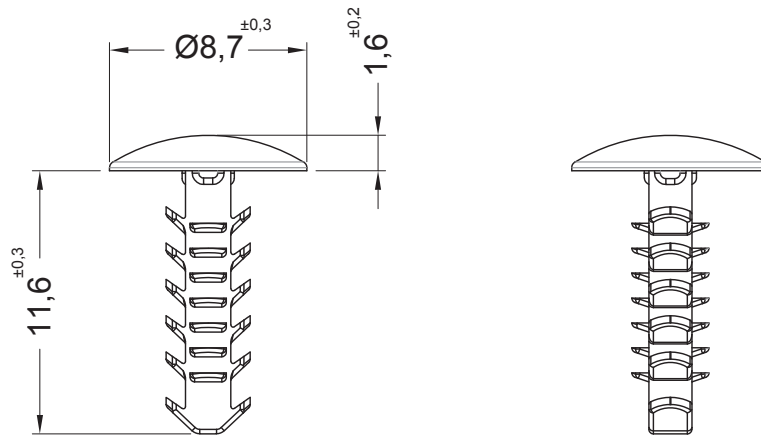

DIM.	TOL.
5mm DOWN	±0.2
5~20mm	±0.3
20~40mm	±0.4
40~60mm	±0.5
60~100mm	±0.8
100mm UP	±1.0

REVISIONS			
REV	DESCRIPTION	DATE	BY



MOUNTING HOLE: Ø3,2
PANEL THICKNESS: 1,6 - 9,5

		TITLE MOUNTING BUTTON	
		MATERIAL PA 66 V2(UL94)	DATE 27/07/2022
PART NUMBER 18212AA00		DRAWING NUMBER	
NATURAL		CHECK	
SIZE A4	SCALE 3:1	UNIT mm.	REV A
UNLESS OTHERWISE SPECIFIED TOLERANCE SEE ABOVE		APPROVED	