

DIM.	TOL.
5mm DOWN	±0.2
5~20mm	±0.3
20~40mm	±0.4
40~60mm	±0.5
60~100mm	±0.8
100mm UP	±1.0

REVISIONS			
REV	DESCRIPTION	DATE	BY

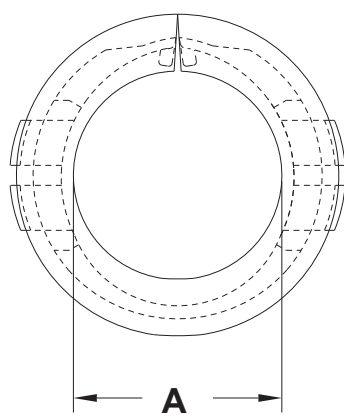
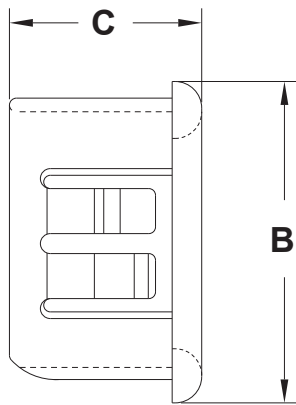

P/N	HOLE	A	B	C	PANEL
18465AA01	Ø13,0	9,0	14,9	10,3	3,2
18466AA01	Ø16,5	12,3	18,6	10,3	3,2
18467AA01	Ø22,0	17,3	24,8	10,3	3,2
18468AA01	Ø25,0	20,1	26,4	10,3	3,2
18469AA01	Ø50,8	43,9	53,9	10,7	3,2
18470AA01	Ø63,5	50,8	66,0	18,3	6,4

WORKING TEMPERATURE: -18°C.....+105°C

		TITLE OPEN/CLOSE BUSHINGS	
		MATERIAL PA66 V2(UL94)	DATE 31/07/2023
PART NUMBER SEE TABLE		DRAWING NUMBER 23.07.31.184X.0.E	
DRAWN A.C.		COLOR BLACK	CHECK
SIZE A4	SCALE NTS	UNIT mm.	REV A
UNLESS OTHERWISE SPECIFIED TOLERANCE SEE ABOVE		APPROVED	