

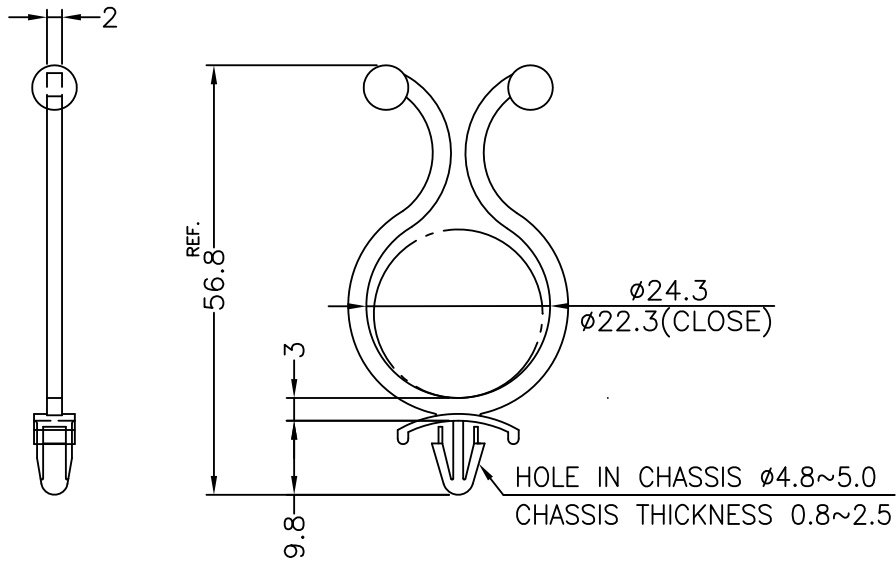

DIM.	TOL
L<5	±0.2
5<L≤20	±0.3
20<L≤40	±0.5
40<L≤60	±0.7
60<L≤100	±0.8
ABOVE 100	±1.0

REVISIONS			
REV	DESCRIPTION	DATE	BY



				TITLE PUSH MOUNT TWIST LOCK			
				MATERIAL PA66 UL94-V2		07/08/2013	
				FINISH		DRAWN V.P.	
PART NUMBER 6548AA00		DRAWING NUMBER 13.08.07.6548.E.0		COLOR NATURAL		CHECK	
SIZE A4	SCALE NONE	UNIT mm	REV	UNLESS OTHERWISE SPECIFIED TOLERANCE SEE ABOVE		APPROVED	