

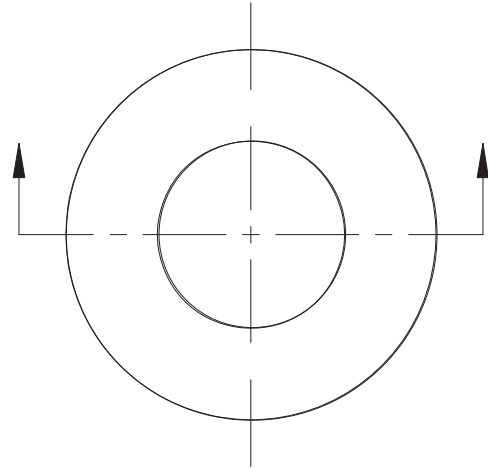

DIM.	TOL.
5mm DOWN	±0.2
5~20mm	±0.3
20~40mm	±0.4
40~60mm	±0.5
60~100mm	±0.8
100mm UP	±1.0

REVISIONS			
REV	DESCRIPTION	DATE	BY

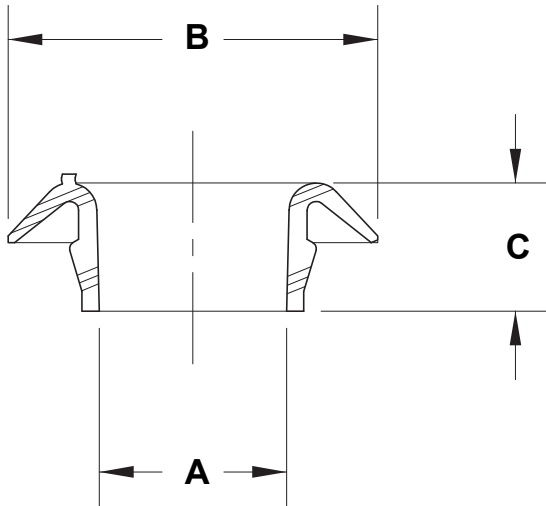

P/N	A	B	C	HOLE
18062PS01	10,4	20,6	7,1	12,7
18063PS01	13,2	23,6	7,9	15,9
18064PS01	16,5	26,9	8,9	19,1
18065PS01	19,6	30,2		22,2
18066PS01	22,6	33,5		22,6
18067PS01	28,4	40,6		31,8

PANEL THICKNESS: FROM 0,8 TO 2,0
 WORKING TEMPERATURE: 0°C ... 50°C

				TITLE RUBBER GROMMETS	
				MATERIAL TPE	
PART NUMBER SEE ABOVE				DRAWING NUMBER 22.06.07.1806X.0.E	
				COLOR BLACK	
SIZE A4	SCALE NTS	UNIT mm.	REV A	UNLESS OTHERWISE SPECIFIED TOLERANCE SEE ABOVE	
				APPROVED	