

REVISIONS			
REV	DESCRIPTION	DATE	BY

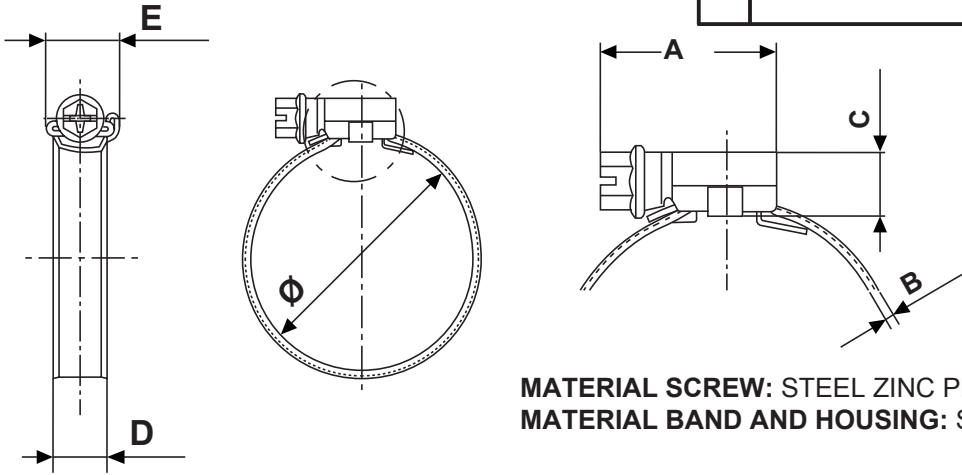

MATERIAL SCREW: STEEL ZINC PLATED
MATERIAL BAND AND HOUSING: STAINLESS STEEL

P/N	A	B	C	D	E	Ø
20700MD90	17,5	0,65	8,4	7,0	10,9	8,0-12,0
20701MD90	22,1	0,65	10,5	9,0	14,0	8,0-16,0
20702MD90	22,1	0,65	10,5	9,0	14,0	12,0-22,0
20703MD90	23,6	0,75	10,5	9,0	14,0	16,0-27,0
20704MD90	23,6	0,75	10,5	9,0	14,0	20,0-32,0
20705MD90	25,6	0,75	10,5	9,0	14,0	25,0-40,0
20706MD90	25,6	0,75	10,5	9,0	14,0	30,0-45,0
20707MD90	25,6	0,75	10,5	9,0	14,0	32,0-50,0
20708MD90	25,6	0,75	10,5	9,0	14,0	40,0-60,0
20709MD90	29,6	0,75	10,5	9,0	14,0	50,0-70,0
20710MD90	29,6	0,75	10,5	9,0	14,0	60,0-80,0
20711MD90	29,6	0,75	10,5	9,0	14,0	70,0-90,0
20712MD90	29,6	0,75	10,5	9,0	14,0	80,0-100,0
20713MD90	29,6	0,75	10,5	9,0	14,0	90,0-110,0
20714MD90	29,6	0,75	10,5	9,0	14,0	100,0-120,0
20715MD90	29,6	0,75	10,5	9,0	14,0	110,0-130,0
20716MD90	29,6	0,75	10,5	9,0	14,0	120,0-140,0
20717MD90	29,6	0,75	10,5	9,0	14,0	130,0-150,0
20718MD90	29,6	0,75	10,5	9,0	14,0	140,0-160,0

NOTES:

VALUES TORQUE (Nm): 3,0

The maximum application pressure can vary depending on the type of hose used and the geometry of the coupling.

PRESSURE (Bar) Max. Values: 45

				TITLE HOSE CLAMP "L" WORM DRIVE CLIP W2	
				MATERIAL SEE ABOVE	
PART NUMBER DRAWING NUMBER 22.05.24.207XX.0.E				DRAWN A.C.	
				FINISH	
SIZE A4	SCALE NTS	UNIT mm.	REV A	UNLESS OTHERWISE SPECIFIED TOLERANCE SEE ABOVE	
				APPROVED	