

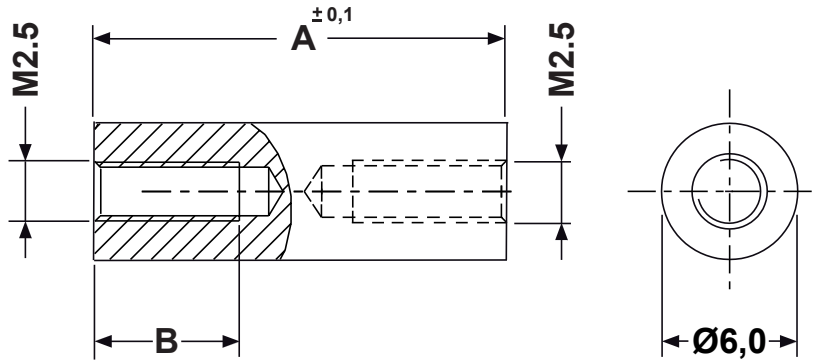

REVISIONS			
REV	DESCRIPTION	DATE	BY



FROM A 5,0 TO A 14,0 THROUGH

P/N	A	B
10039BB0104.0	4.0	4.0
10039BB0105.0	5.0	5.0
10039BB0106.0	6.0	6.0
10039BB0107.0	7.0	7.0
10039BB0108.0	8.0	8.0
10039BB0109.0	9.0	9.0
10039BB0110.0	10.0	10.0
10039BB0111.0	11.0	11.0
10039BB0112.0	12.0	12.0
10039BB0113.0	13.0	13.0
10039BB0114.0	14.0	14.0
10039BB0115.0	15.0	7.0
10039BB0116.0	16.0	7,5
10039BB0117.0	17.0	8.0
10039BB0118.0	18.0	8,5
10039BB0119.0	19.0	9.0
10039BB0120.0	20.0	9,5
10039BB0121.0	21.0	10.0
10039BB0122.0	22.0	10.0
10039BB0123.0	23.0	10.0
10039BB0124.0	24.0	10.0
10039BB0125.0	25.0	10.0
10039BB0126.0	26.0	10.0
10039BB0127.0	27.0	10.0
10039BB0128.0	28.0	10.0
10039BB0129.0	29.0	10.0
10039BB0130.0	30.0	10.0

P/N	A	B
10039BB0131.0	31.0	10.0
10039BB0132.0	32.0	10.0
10039BB0133.0	33.0	10.0
10039BB0134.0	34.0	10.0
10039BB0135.0	35.0	10.0
10039BB0136.0	36.0	10.0
10039BB0137.0	37.0	10.0
10039BB0138.0	38.0	10.0
10039BB0139.0	39.0	10.0
10039BB0140.0	40.0	10.0
10039BB0141.0	41.0	10.0
10039BB0142.0	42.0	10.0
10039BB0143.0	43.0	10.0
10039BB0144.0	44.0	10.0
10039BB0145.0	45.0	10.0
10039BB0146.0	46.0	10.0
10039BB0147.0	47.0	10.0
10039BB0148.0	48.0	10.0
10039BB0149.0	49.0	10.0
10039BB0150.0	50.0	10.0
10039BB0151.0	51.0	10.0
10039BB0152.0	52.0	10.0
10039BB0153.0	53.0	10.0
10039BB0154.0	54.0	10.0
10039BB0155.0	55.0	10.0

		TITLE ROUND Ø 5,0 F/F METRIC M2 SPACERS	
		MATERIAL PA 6 25%GV HB(UL94)	DATE 18/05/2022
PART NUMBER SEE ABOVE		DRAWING NUMBER 22.05.18.10039.0.E	
DRAWN A.C.		COLOR BLACK	CHECK
SIZE A4	SCALE NTS	UNIT mm.	REV A
UNLESS OTHERWISE SPECIFIED TOLERANCE SEE ABOVE		APPROVED	