

DIM.	TOL.
5mm DOWN	±0.2
5~20mm	±0.3
20~40mm	±0.4
40~60mm	±0.5
60~100mm	±0.8
100mm UP	±1.0

REVISIONS			
REV	DESCRIPTION	DATE	BY

THREAD DEEP	
A	F
8,0	6,0
9,0	7,0
10,0	8,0
11,0	9,0
12,0 - 65,0	10,0

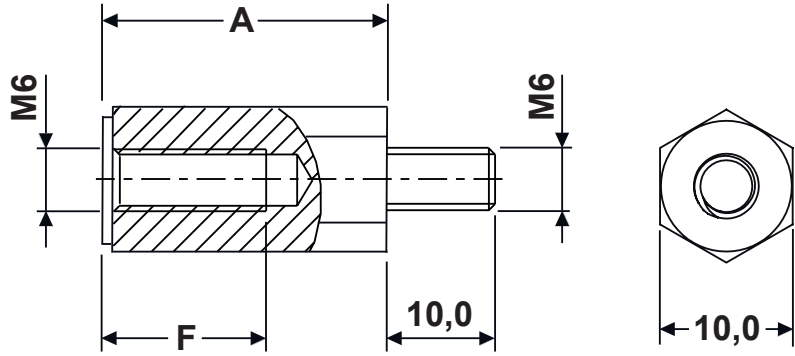

P/N	A
10023AA0108.0	8.0
10023AA0109.0	9.0
10023AA0110.0	10.0
10023AA0111.0	11.0
10023AA0112.0	12.0
10023AA0113.0	13.0
10023AA0114.0	14.0
10023AA0115.0	15.0
10023AA0116.0	16.0
10023AA0117.0	17.0
10023AA0118.0	18.0
10023AA0119.0	19.0
10023AA0120.0	20.0
10023AA0121.0	21.0
10023AA0122.0	22.0
10023AA0123.0	23.0
10023AA0124.0	24.0
10023AA0125.0	25.0
10023AA0126.0	26.0
10023AA0127.0	27.0

P/N	A
10023AA0128.0	28.0
10023AA0129.0	29.0
10023AA0130.0	30.0
10023AA0131.0	31.0
10023AA0132.0	32.0
10023AA0133.0	33.0
10023AA0134.0	34.0
10023AA0135.0	35.0
10023AA0136.0	36.0
10023AA0137.0	37.0
10023AA0138.0	38.0
10023AA0139.0	39.0
10023AA0140.0	40.0
10023AA0141.0	41.0
10023AA0142.0	42.0
10023AA0143.0	43.0
10023AA0144.0	44.0
10023AA0145.0	45.0
10023AA0146.0	46.0
10023AA0147.0	47.0

P/N	A
10023AA0148.0	48.0
10023AA0149.0	49.0
10023AA0150.0	50.0
10023AA0151.0	51.0
10023AA0152.0	52.0
10023AA0153.0	53.0
10023AA0154.0	54.0
10023AA0155.0	55.0
10023AA0156.0	56.0
10023AA0157.0	57.0
10023AA0158.0	58.0
10023AA0159.0	59.0
10023AA0160.0	60.0
10023AA0161.0	61.0
10023AA0162.0	62.0
10023AA0163.0	63.0
10023AA0164.0	64.0
10023AA0165.0	65.0

**WORKING TEMPERATURE: -35°C ~ +130°C**

		TITLE <b>HEXAGONAL METRIC THREADED SPACERS</b>	
		MATERIAL PA66 HB(UL94)	DATE 23/04/2021
PART NUMBER SEE TABLE		DRAWN R.F.	
DRAWING NUMBER 21.04.23.10023.0.E		CHECK	
SIZE A4	SCALE NTS	COLOR BLACK	APPROVED
UNIT mm.	REV A	UNLESS OTHERWISE SPECIFIED TOLERANCE SEE ABOVE	