

REVISIONS			
REV	DESCRIPTION	DATE	BY

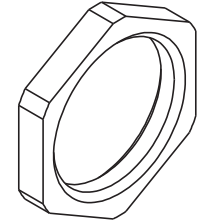

P/N	A	B	C
15182MA92	M 12 x 150	15,0	3,0
15183MA92	M 16 x 150	20,0	3,0
15184MA92	M 20 x 150	24,0	3,5
15185MA92	M 25 x 150	30,0	3,5
15186MA92	M 32 x 150	35,0	4,5
15187MA92	M 40 x 150	45,0	4,5
15188MA92	M 50 x 150	55,0	5,5
15189MA92	M 63 x 150	70,0	6,0

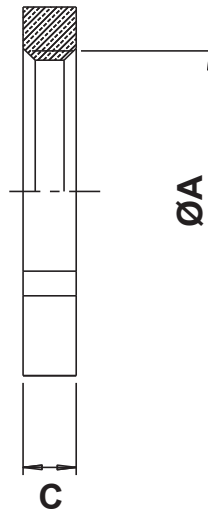
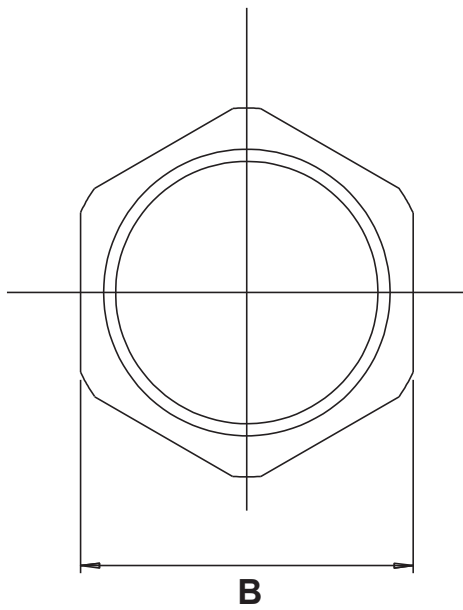

TITLE
BRASS METRIC THREAD HEXAGONAL LOCKNUTS

MATERIAL
NICKEL PLATED BRASS

DATE
08/03/2022

DRAWN
A.C.

CHECK

PART NUMBER
SEE TABLE

DRAWING NUMBER
22.03.08.151XX.0.E

SIZE
A4

SCALE
NTS

UNIT
mm.

REV
A

UNLESS OTHERWISE SPECIFIED TOLERANCE

APPROVED