

Dimensions	Tolerance
5mm DOWN	±0.2
5~20mm	±0.3
20~40mm	±0.4
40~60mm	±0.5
60~100mm	±0.8
100mm UP	±1.0

REVISIONS			
REV	DESCRIPTION	DATE	BY

P/N	A
10091BB0102.0	2.0
10091BB0103.0	3.0
10091BB0104.0	4.0
10091BB0105.0	5.0
10091BB0106.0	6.0
10091BB0107.0	7.0
10091BB0108.0	8.0
10091BB0109.0	9.0
10091BB0110.0	10.0
10091BB0111.0	11.0
10091BB0112.0	12.0
10091BB0113.0	13.0
10091BB0114.0	14.0
10091BB0115.0	15.0
10091BB0116.0	16.0
10091BB0117.0	17.0
10091BB0118.0	18.0
10091BB0119.0	19.0
10091BB0120.0	20.0
10091BB0121.0	21.0
10091BB0122.0	22.0
10091BB0123.0	23.0
10091BB0124.0	24.0
10091BB0125.0	25.0
10091BB0126.0	26.0
10091BB0127.0	27.0
10091BB0128.0	28.0
10091BB0129.0	29.0
10091BB0130.0	30.0

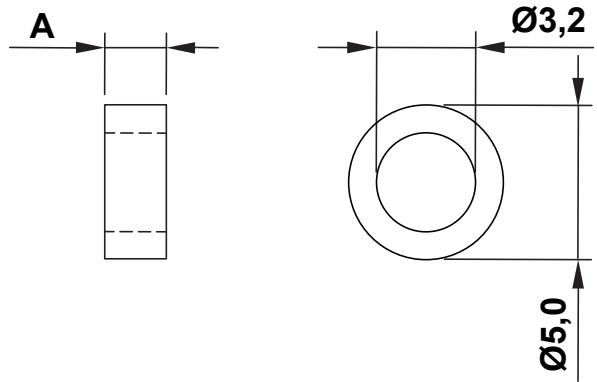

NOTES:
SCREWS NOT INCLUDED
LENGTHS AVAILABLE IN INCREMENTS OF 1 mm

DESCRIPTION		TITLE: ROUND P.C.B SPACER		DWG UNIT: MM	
MATERIAL: PA 6 25% GF		Modelled in RHINO 4.0 FILE:		DwN: 22/03/09.10091.0.E ChkD:	
COLOUR: Black		TOLLERANCES		SHEET: 1 OF 1 DT: 09/03/22 Part Number: SEE TABLE	
WORKING TEMPERATURE: -30°C - + 100°C		SEE ABOVE		SCALE: NTS	
FLAMMABILITY: HB (UL94)					
REV.					