

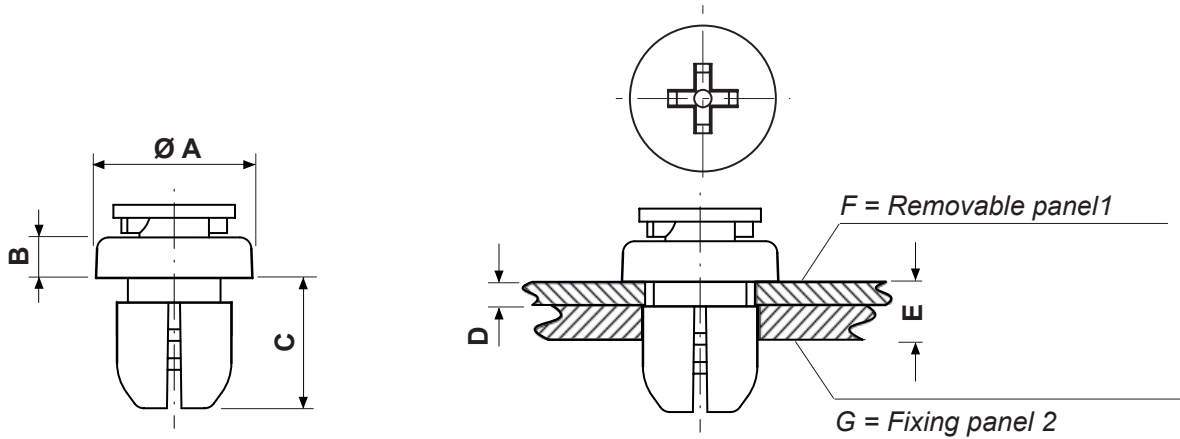

DIM.	TOL.
5mm DOWN	±0.2
5~20mm	±0.3
20~40mm	±0.4
40~60mm	±0.5
60~100mm	±0.8
100mm UP	±1.0

REVISIONS			
REV	DESCRIPTION	DATE	BY



P/N	A	B	C	D	E	F	G
9868NC01 + 9872NC01	10,8	2,7	9,0	1,6	2,5 - 4,2	Ø 7,6	Ø 8,1
9870NC01 + 9874NC01	10,8	2,7	10,0	2,5	3,5 - 5,2	Ø 7,6	Ø 8,1
9869NC01 + 9873NC01	9,2	2,7	8,5	1,6	2,5 - 4,2	Ø 6,0	Ø 6,4
9871NC01 + 9875NC01	9,2	2,7	9,5	2,5	3,5 - 5,2	Ø 6,0	Ø 6,4

				TITLE QUARTER TURN LATCH			
				MATERIAL PC 66 V2 (UL64)		DATE 01/12/2021	
PART NUMBER SEE ABOVE		DRAWING NUMBER 21.12.01.9868 .0.E		COLOR BLACK		CHECK	
SIZE A4	SCALE NTS	UNIT mm.	REV A	UNLESS OTHERWISE SPECIFIED TOLERANCE SEE ABOVE		APPROVED	