

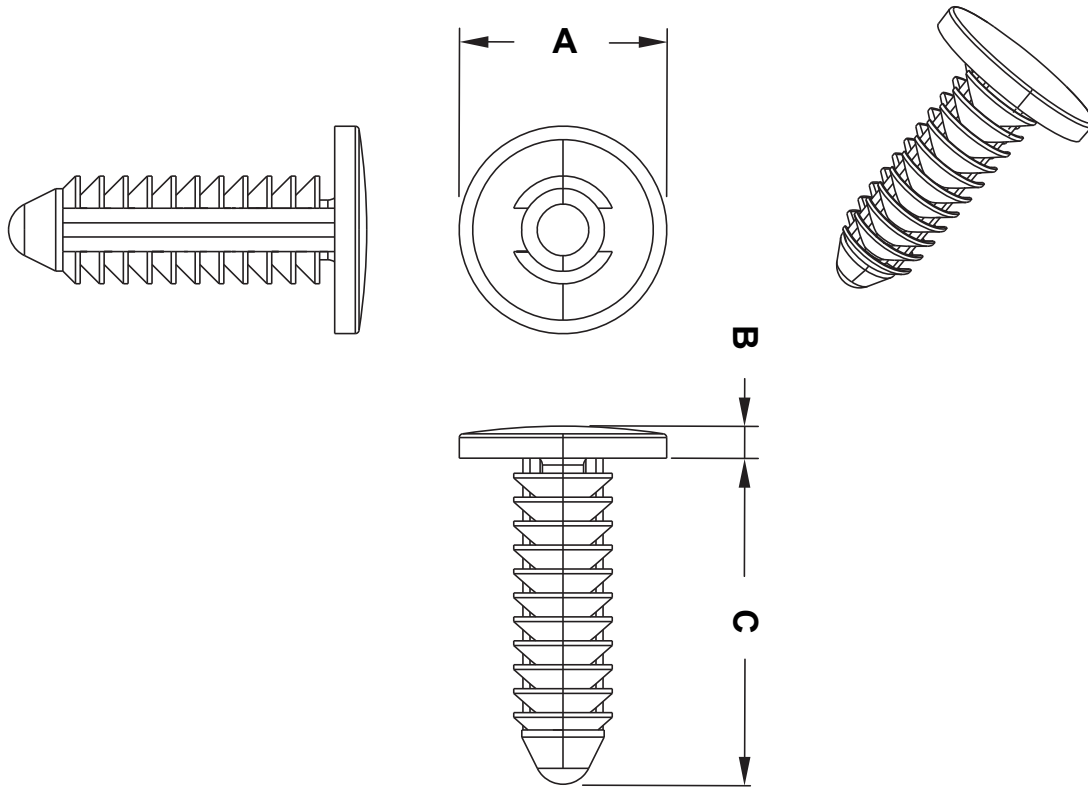

DIM.	TOL.
5mm DOWN	±0.2
5~20mm	±0.3
20~40mm	±0.4
40~60mm	±0.5
60~100mm	±0.8
100mm UP	±1.0

REVISIONS			
REV	DESCRIPTION	DATE	BY



P/N	A	B	C	Hole	Thickness
8212AA01	11,0	1,7	17,3	Ø 4,8	0,7 - 13,0
8218AA01	17,8	2,4	15,5	Ø 6,0 - 6,3	2,3 - 8,9
8219AA01	17,8	2,4	20,4	Ø 6,0 - 6,3	2,5 - 12,0
8221AA01	19,1	0,9	15,9	Ø 6,4	2,7 - 7,3
8220AA01	17,8	2,5	35,1	Ø 6,4	10,7 - 28,8
8224AA01	19,0	2,0	30,5	Ø 7,2	1,5 - 25,4
8225AA01	16,6	2,1	19,1	Ø 8,7	1,4 - 13,0
8226AA01	21,2	4,0	28,2	Ø 10,0	1,5 - 21,2

				TITLE <b>TOOTHED CLIP</b>	
				MATERIAL PA66 V2(UL94)	
PART NUMBER SEE ABOVE				DRAWN A.C.	
				DRAWING NUMBER 21.12.01.82XX.0.E	
SIZE A4		SCALE NTS		COLOR BLACK	
UNIT mm.		REV A		UNLESS OTHERWISE SPECIFIED TOLERANCE SEE ABOVE	
				APPROVED	