

DIM.	TOL.
5mm DOWN	±0.2
5~20mm	±0.3
20~40mm	±0.4
40~60mm	±0.5
60~100mm	±0.8
100mm UP	±1.0

REVISIONS			
REV	DESCRIPTION	DATE	BY

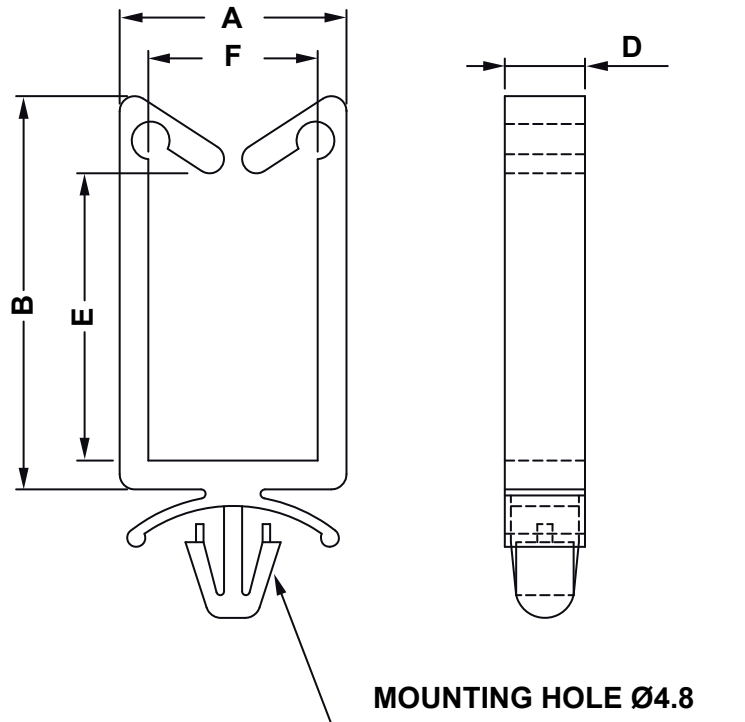

WORKING TEMPERATURE: -20°C +85°C

P/N	A	B	D	E	F	Thickness
5595AA00	15,0	17,0	5,3	10,0	11,2	0,8 - 2,0
6249AA00	15,0	12,0	5,3	5,0	11,2	0,8 - 2,0
6250AA00	15,0	26,0	5,3	19,0	11,2	0,8 - 2,0
6251AA00	15,0	34,0	5,3	27,0	11,2	0,8 - 2,0
9660AA00	15,5	13,0	5,6	4,8	11,1	2,6 - 3,6
9661AA00	15,5	18,0	5,6	9,7	11,1	2,6 - 3,6
9662AA00	15,5	26,9	5,6	18,5	11,1	2,6 - 3,6
9663AA00	15,5	34,8	5,6	26,5	11,1	2,6 - 3,6

		TITLE WIRE CLIP - TOP OPENING	
		MATERIAL PA66 V2(UL94)	DATE 14/12/2021
PART NUMBER SEE TABLE		DRAWING NUMBER 21.12.14.5595.0.E	
DRAWN A.C.		COLOR NATURAL	CHECK
SIZE A4	SCALE NTS	UNIT mm.	REV A
UNLESS OTHERWISE SPECIFIED TOLERANCE SEE ABOVE		APPROVED	