

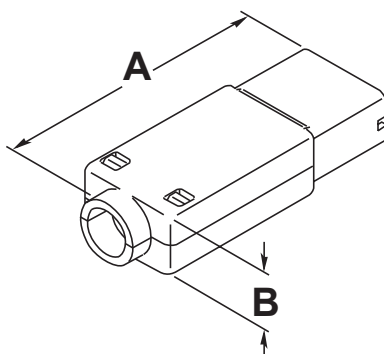

DIM.	TOL.
5mm DOWN	±0.2
5~20mm	±0.3
20~40mm	±0.4
40~60mm	±0.5
60~100mm	±0.8
100mm UP	±1.0

REVISIONS			
REV	DESCRIPTION	DATE	BY

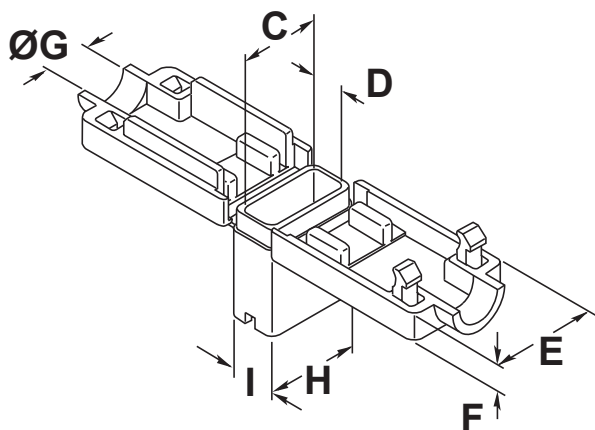

P/N	A	B	C	D	E	F	ØG	H	I	Material	Colour
11628AA00	22,3	4,6	4,1	2,3	8,0	2,3	3,0	6,0	3,9	PA 6.6 V0(UL94)	Natural
11629AA00	21,9	5,2	6,1	2,6	8,8	2,6	3,6	7,5	3,9	PA 6.6 V0(UL94)	Natural
11630AA00	24,6	5,2	6,8	2,9	8,8	2,6	3,6	8,5	4,4	PA 6.6 V0(UL94)	Natural
11631AA00	26,0	5,6	8,0	3,4	9,8	2,8	4,1	9,3	4,7	PA 6.6 V0(UL94)	Natural
11628AR02	22,3	4,6	4,1	2,3	8,0	2,3	3,0	6,0	3,9	PA 6 V2(UL94)	White
11629AR02	21,9	5,2	6,1	2,6	8,8	2,6	3,6	7,5	3,9	PA 6 V2(UL94)	White
11630AR02	24,6	5,2	6,8	2,9	8,8	2,6	3,6	8,5	4,4	PA 6 V2(UL94)	White
11631AR02	26,0	5,6	8,0	3,4	9,8	2,8	4,1	9,3	4,7	PA 6 V2(UL94)	White

				TITLE CAPS	
				MATERIAL SEE TABLE	
PART NUMBER SEE TABLE				DRAWING NUMBER 21.12.03.11XX.0.E	
DRAWING NUMBER 21.12.03.11XX.0.E				DRAWN A.C.	
DRAWING NUMBER 21.12.03.11XX.0.E				CHECK	
DRAWING NUMBER 21.12.03.11XX.0.E				APPROVED	
SIZE A4		SCALE NTS		UNIT mm.	
SIZE A4		SCALE NTS		REV A	
UNLESS OTHERWISE SPECIFIED TOLERANCE SEE ABOVE				APPROVED	