

REVISIONS			
REV	DESCRIPTION	DATE	BY

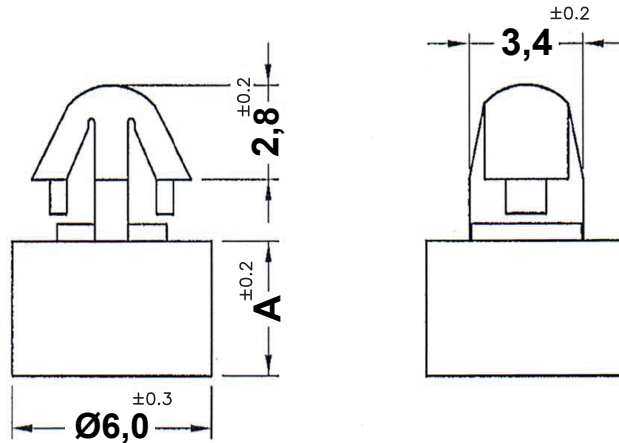

**MOUNTING HOLE Ø 3,5
PANEL THICKNESS 1,2 - 1,7**

P/N	A
11435AA0003.0	3.0
11435AA0003.5	3.5
11435AA0004.5	4.0



fastpoint		TITLE SPACER SUPPORT		
		MATERIAL PA 66 V2(UL94)	DATE 09/12/2021	
			DRAWN R.F.	
		COLOR NATURAL	CHECK	
PART NUMBER SEE TABLE	DRAWING NUMBER 21.12.09.11435.0.E	UNLESS OTHERWISE SPECIFIED TOLERANCE		
SIZE A4	SCALE NTS	UNIT mm.	REV A	APPROVED