

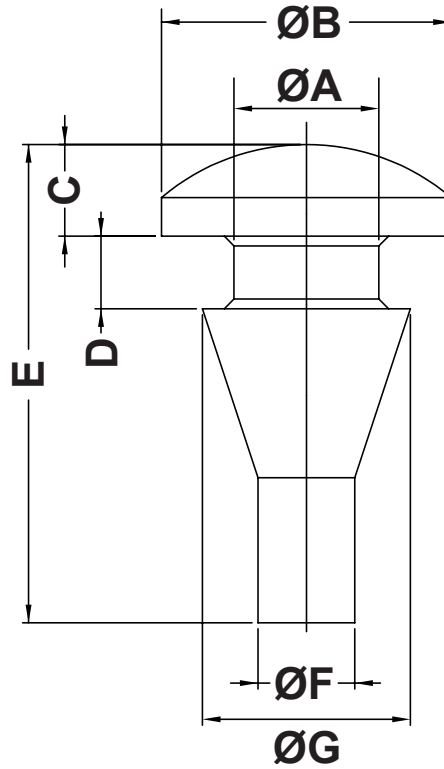

DIM.	TOL.
5mm DOWN	±0.2
5~20mm	±0.3
20~40mm	±0.4
40~60mm	±0.5
60~100mm	±0.8
100mm UP	±1.0

REVISIONS			
REV	DESCRIPTION	DATE	BY



P/N	A	B	C	D	E	F	G	Material
11232GS01	2,6	4,9	2,5	1,5	12,0	2,2	4,0	EPDM 70 Shore A
11233GS01	3,0	6,0	1,9	1,5	9,9	2,0	4,3	EPDM 50 Shore A
11235GS01	4,0	10,0	4,0	4,0	18,0	3,0	7,0	EPDM 40 Shore A
11238GS01	6,0	13,0	5,5	1,3	14,3	5,0	8,0	EPDM 50 Shore A

NOTES:
-WORKING TEMPERATURE:
EPDM: -40°C ~ + 120°C

		TITLE BUMPER	
		MATERIAL SEE ABOVE	DATE 07/12/2021
PART NUMBER SEE TABLE		DRAWING NUMBER 21.12.07.11232.0.E	
DRAWN A.C.		CHECK	
SIZE A4	SCALE NTS	UNIT mm.	REV A
COLOR BLACK		UNLESS OTHERWISE SPECIFIED TOLERANCE SEE ABOVE	
APPROVED			