

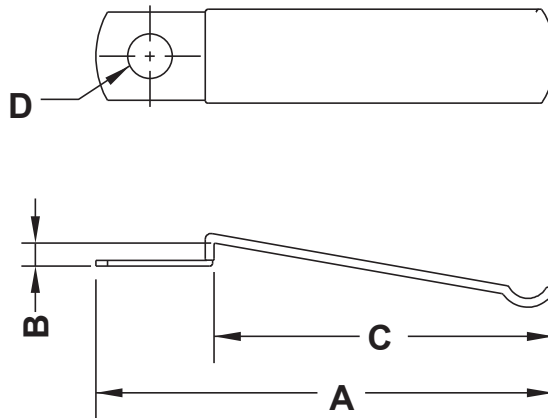

REVISIONS			
REV	DESCRIPTION	DATE	BY



P/N	A	B	C	D
15858MD90PS	40,9	2,3	30,2	4,0
15859MD90PS	66,8	2,3	56,9	4,0

**MATERIAL**  
**BODY: STAINLESS STEEL, W/VINYL COATING .02 (0,5 MM) THICK**  
**COATING: SOFT, PVC, .032 (0,8 MM) MINIMUM THICKNESS**

				TITLE <b>VINYL COATED STEEL CLAMPS</b>	
				MATERIAL SEE ABOVE	
PART NUMBER SEE TABLE				DRAWN R.F.	
DRAWING NUMBER 21.11.03.XXXX.0.E				CHECK	
SIZE A4	SCALE NTS	UNIT mm.	REV A	UNLESS OTHERWISE SPECIFIED TOLERANCE SEE ABOVE	
				APPROVED	