

DIM.	TOL.
5mm DOWN	±0.2
5~20mm	±0.3
20~40mm	±0.4
40~60mm	±0.5
60~100mm	±0.8
100mm UP	±1.0

REVISIONS			
REV	DESCRIPTION	DATE	BY

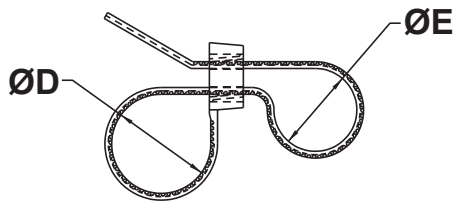

$\text{ØD} - \text{ØE} = \text{ØF}$
(MAXIMUM COMBINED BUNDLE)

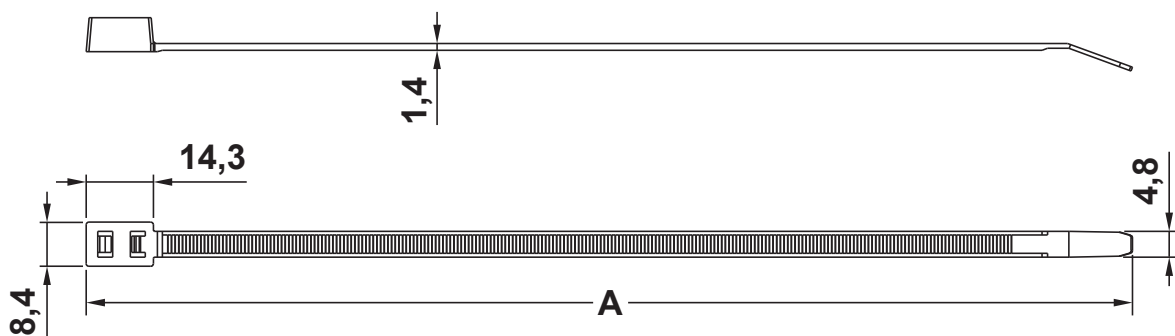

P/N	A	COLOUR	MAX.COMBINED BUNDLE FØ	TENSILE STRENGTH
12906AA00	195,0	NATURAL	45,0	222 N
12906AA01	195,0	BLACK	45,0	222 N
12907AA00	225,0	NATURAL	52,0	222 N
12907AA01	225,0	BLACK	52,0	222 N
12908AA00	300,0	NATURAL	76,0	222 N
12908AA01	300,0	BLACK	76,0	222 N



TITLE **DOUBLE LOOP CABLE TIES**

MATERIAL PA 66 V2(UL94)

DATE 06/05/2019

DRAWN R.F.

COLOR SEE ABOVE

CHECK

PART NUMBER SEE TABLE

DRAWING NUMBER 19.05.06.1290X.0.E

UNLESS OTHERWISE SPECIFIED TOLERANCE SEE ABOVE

APPROVED

SIZE A4

SCALE NTS

UNIT mm.

REV A