

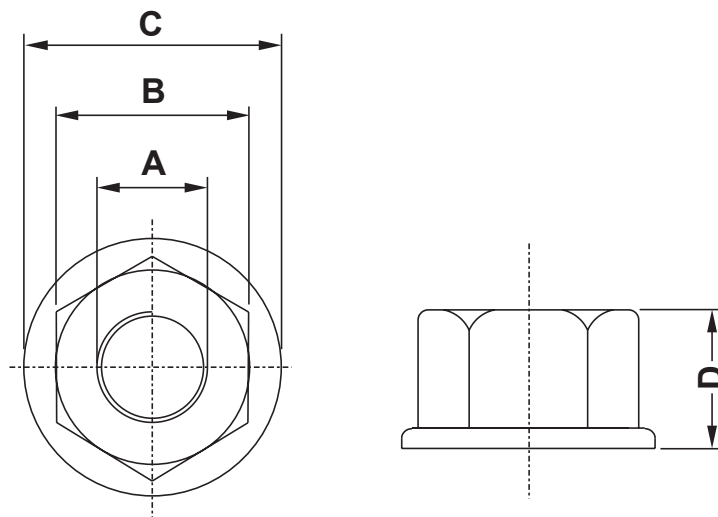

DIM.	TOL.
5mm DOWN	±0.2
5~20mm	±0.3
20~40mm	±0.4
40~60mm	±0.5
60~100mm	±0.8
100mm UP	±1.0

REVISIONS			
REV	DESCRIPTION	DATE	BY



P/N	A	B	C	D
10432AA00	M 3	5,5	7,0	2,3
10433AA00	M 4	7,0	9,4	4,1
10434AA00	M 5	8,0	11,0	5,1
10435AA00	M 6	10,0	13,0	6,0
10436AA00	M 8	13,0	17,0	8,0
10437AA00	M 10	16,0	22,0	9,5

		TITLE <b>HEXAGONAL NUTS WITH FLANGE</b>	
		MATERIAL PA 6	DATE 19/11/2021
PART NUMBER SEE TABLE		DRAWING NUMBER 21.11.19.1043X.0.E	
DRAWN R.F.		COLOR NATURAL	CHECK
SIZE A4	SCALE NTS	UNIT mm.	REV A
UNLESS OTHERWISE SPECIFIED TOLERANCE SEE ABOVE		APPROVED	