

DIM.	TOL.
5mm DOWN	±0.2
5~20mm	±0.3
20~40mm	±0.4
40~60mm	±0.5
60~100mm	±0.8
100mm UP	±1.0

REVISIONS			
REV	DESCRIPTION	DATE	BY

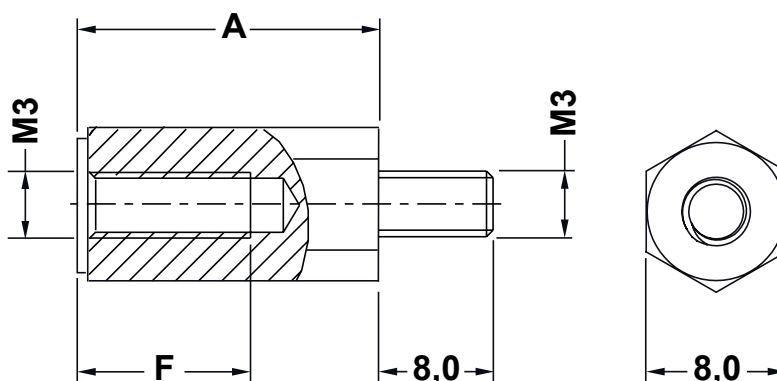

P/N	A	F
6923AA0105.0	5.0	3.0
6923AA0106.0	6.0	4.0
6923AA0107.0	7.0	5.0
6923AA0108.0	8.0	6.0
6923AA0109.0	9.0	7.0
6923AA0110.0	10.0	8.0
6923AA0111.0	11.0	9.0
6923AA0112.0	12.0	10.0
6923AA0113.0	13.0	10.0
6923AA0114.0	14.0	10.0
6923AA0115.0	15.0	10.0
6923AA0116.0	16.0	10.0
6923AA0117.0	17.0	10.0
6923AA0118.0	18.0	10.0
6923AA0119.0	19.0	10.0
6923AA0120.0	20.0	10.0
6923AA0121.0	21.0	10.0
6923AA0122.0	22.0	10.0
6923AA0123.0	23.0	10.0
6923AA0124.0	24.0	10.0
6923AA0125.0	25.0	10.0
6923AA0126.0	26.0	10.0

P/N	A	F
6923AA0127.0	27.0	10.0
6923AA0128.0	28.0	10.0
6923AA0129.0	29.0	10.0
6923AA0130.0	30.0	10.0
6923AA0131.0	31.0	10.0
6923AA0132.0	32.0	10.0
6923AA0133.0	33.0	10.0
6923AA0134.0	34.0	10.0
6923AA0135.0	35.0	10.0
6923AA0136.0	36.0	10.0
6923AA0137.0	37.0	10.0
6923AA0138.0	38.0	10.0
6923AA0139.0	39.0	10.0
6923AA0140.0	40.0	10.0
6923AA0141.0	41.0	10.0
6923AA0142.0	42.0	10.0
6923AA0143.0	43.0	10.0
6923AA0144.0	44.0	10.0
6923AA0145.0	45.0	10.0
6923AA0146.0	46.0	10.0
6923AA0147.0	47.0	10.0
6923AA0148.0	48.0	10.0

P/N	A	F
6923AA0149.0	49.0	10.0
6923AA0150.0	50.0	10.0
6923AA0151.0	51.0	10.0
6923AA0152.0	52.0	10.0
6923AA0153.0	53.0	10.0
6923AA0154.0	54.0	10.0
6923AA0155.0	55.0	10.0
6923AA0156.0	56.0	10.0
6923AA0157.0	57.0	10.0
6923AA0158.0	58.0	10.0
6923AA0159.0	59.0	10.0
6923AA0160.0	60.0	10.0
6923AA0161.0	61.0	10.0

**SPECIAL LENGTHS AVAILABLE BY SPECIAL REQUEST**

				TITLE <b>HEXAGONAL METRIC THREADED SPACER</b>	
				MATERIAL PA6.6 HB (UL94)	DATE 13/09/2021
PART NUMBER SEE TABLE				DRAWING NUMBER 21.09.13.6923.0.E	
				COLOR BLACK	CHECK
SIZE A4	SCALE NTS	UNIT mm.	REV A	UNLESS OTHERWISE SPECIFIED TOLERANCE SEE ABOVE	
				APPROVED	