

DIM.	TOL.
5mm DOWN	±0.2
5~20mm	±0.3
20~40mm	±0.4
40~60mm	±0.5
60~100mm	±0.8
100mm UP	±1.0

REVISIONS			
REV	DESCRIPTION	DATE	BY

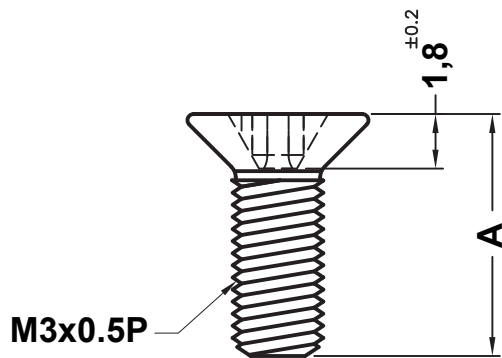

P/N	A
15792PK0004.0	4.0
15792PK0005.0	5.0
15792PK0006.0	6.0
15792PK0008.0	8.0
15792PK0010.0	10.0
15792PK0012.0	12.0
15792PK0014.0	14.0
15792PK0015.0	15.0
15792PK0017.0	17.0
15792PK0018.0	18.0
15792PK0020.0	20.0

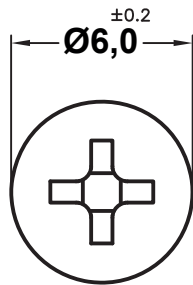

<b>TITLE</b> <b>SCREW</b>		<b>MATERIAL</b> PEEK V0(UL94)		<b>DATE</b> 10/09/2021
		<b>COLOR</b> NATURAL		<b>DRAWN</b> R.F.
<b>PART NUMBER</b> SEE TABLE		<b>DRAWING NUMBER</b> 21.09.10.XXXX.0.E		<b>CHECK</b>
<b>SIZE</b> A4	<b>SCALE</b> 4:1	<b>UNIT</b> mm.	<b>REV</b> A	<b>UNLESS OTHERWISE SPECIFIED TOLERANCE</b> SEE ABOVE
<b>APPROVED</b>				