

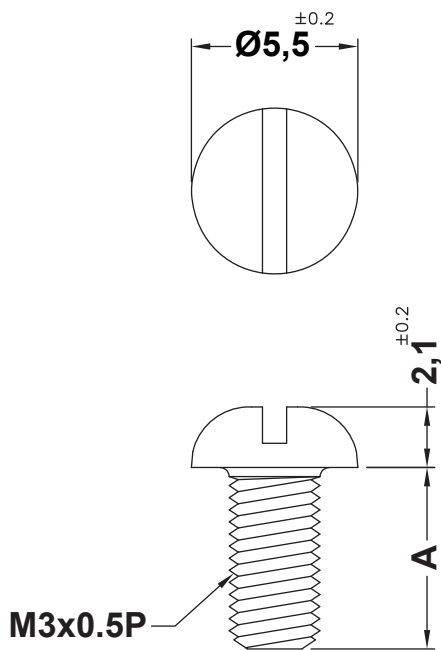

DIM.	TOL
L ≤ 10	±0.2
10 < L ≤ 30	±0.3
30 < L ≤ 50	±0.5
50 < L ≤ 100	±0.7
100 < L ≤ 250	±1.2
ABOVE 250	±1.5

REVISIONS			
REV	DESCRIPTION	DATE	BY



P/N	A
15791PK0004.0	4,0
15791PK0005.0	5,0
15791PK0006.0	6,0
15791PK0008.0	8,0
15791PK0010.0	10,0
15791PK0012.0	12,0
15791PK0014.0	14,0
15791PK0015.0	15,0
15791PK0017.0	17,0
15791PK0018.0	18,0
15791PK0020.0	20,0
15791PK0025.0	25,0
15791PK0030.0	30,0

				TITLE <b>PEEK SCREW WITH SLIT</b>	
				MATERIAL PEEK V0(UL94)	DATE 01/09/2021
PART NUMBER SEE TABLE				DRAWN R.F.	
				DRAWING NUMBER 21.09.01.XXXX.0.E	
SIZE A4				COLOR NATURAL	
				UNLESS OTHERWISE SPECIFIED TOLERANCE SEE ABOVE	
SCALE 4:1		UNIT mm.		REV A	
APPROVED				CHECK	