

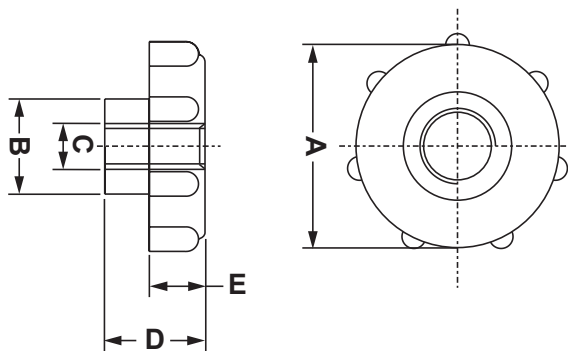

DIM.	TOL.
5mm DOWN	±0.2
5~20mm	±0.3
20~40mm	±0.4
40~60mm	±0.5
60~100mm	±0.8
100mm UP	±1.0

REVISIONS			
REV	DESCRIPTION	DATE	BY



P/N	A	B	C	D	E	DIN
10403AA00	16,0	10,0	M 4	6,0	4,5	DIN 467
10406AA00	20,0	10,0	M 4	6,5	5,0	DIN 467
10399AA00	16,0	9,5	M 4	8,0	4,5	DIN 466
10404AA00	16,0	10,0	M 5	6,0	4,5	DIN 467
10400AA00	16,0	9,5	M 5	8,0	4,5	DIN 466
10407AA00	20,0	10,0	M 5	6,5	5,0	DIN 467
10409AA00	24,0	10,0	M 5	7,5	5,7	DIN 467
10405AA00	16,0	10,0	M 6	6,0	4,5	DIN 467
10401AA00	16,0	9,5	M 6	8,0	4,5	DIN 466
10408AA00	20,0	10,0	M 6	6,5	5,0	DIN 467
10402AA00	24,0	13,0	M 6	11,0	6,0	DIN 466
10410AA00	24,0	10,0	M 6	7,5	5,7	DIN 467

		TITLE <b>KNURLED NUT</b>	
		MATERIAL PA 6	DATE 15/09/2021
PART NUMBER SEE TABLE		DRAWING NUMBER 21.09.15.XXXX.0.E	
DRAWN R.F.		COLOR NATURAL	CHECK
SIZE A4	SCALE NTS	UNIT mm.	REV A
UNLESS OTHERWISE SPECIFIED TOLERANCE SEE ABOVE		APPROVED	