

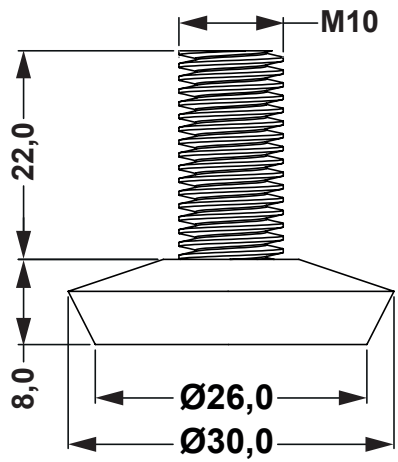

REVISIONS			
REV	DESCRIPTION	DATE	BY



**NOTES:**  
**FEET MATERIAL: PE**  
**SCREW MATERIAL: ZINC PLATED IRON**

				TITLE <b>ADJUSTABLE LEVELING FEETS</b>	
				MATERIAL SEE ABOVE	DATE 26/07/2021
PART NUMBER 5325EA01FS				DRAWN R.F.	
				DRAWING NUMBER 21.07.26.5325.0.E	
SIZE A4				COLOR BLACK	
				UNIT mm.	
SCALE NTS				CHECK	
				REV A	
UNIT mm.				UNLESS OTHERWISE SPECIFIED TOLERANCE SEE ABOVE	
				APPROVED	