

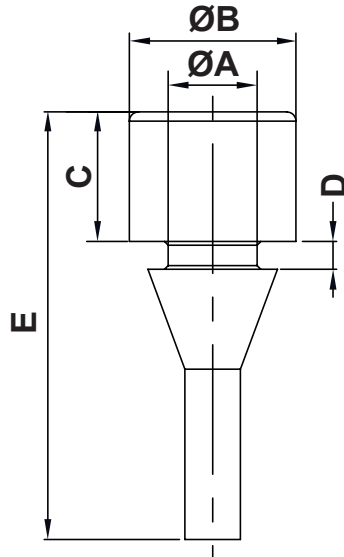

REVISIONS			
REV	DESCRIPTION	DATE	BY



P/N	A	B	C	D	E	Material
11241GS01	2,8	5,2	2,4	1,2	13,2	EPDM 70 Shore A
11242GS01	3,0	6,0	2,0	0,6	8,6	EPDM 50 Shore A
11243GS01	3,0	7,0	2,0	2,0	16,0	EPDM 50 Shore A
11244GS01	4,0	12,0	4,5	2,7	18,5	EPDM 60 Shore A
11245GS01	4,0	10,0	3,0	2,0	12,0	EPDM 40 Shore A
11246GS01	4,8	9,0	7,0	1,5	23,1	EPDM 60 Shore A
11247SI01	7,0	14,0	6,0	1,2	30,0	SILICONE 50 Shore A

WORKING TEMPERATURE:
EPDM: -40°C ~ +130°C
SILICONE: -60°C ~ +250°C

				TITLE BUMPER	
				MATERIAL SEE TABLE	
PART NUMBER SEE TABLE				DRAWING NUMBER 21.07.26.10XX.0.E	
				COLOR BLACK	
SIZE A4	SCALE NTS	UNIT mm.	REV A	UNLESS OTHERWISE SPECIFIED TOLERANCE SEE ABOVE	
				APPROVED	