

DIM.	TOL.
5mm DOWN	±0.2
5~20mm	±0.3
20~40mm	±0.4
40~60mm	±0.5
60~100mm	±0.8
100mm UP	±1.0

REVISIONS			
REV	DESCRIPTION	DATE	BY

P/N	A	B	C	D
3309HA01	∅ 12,0	2,0	7,0	1,0
3310HA01	∅ 12,0	2,0	7,0	1,2
3319HA01	∅ 15,0	2,5	8,5	1,0
3320HA01	∅ 15,0	2,5	8,5	1,2
3321HA01	∅ 15,0	2,5	8,5	1,5
3331HA01	∅ 16,0	3,0	8,0	1,0
3332HA01	∅ 16,0	3,0	8,0	1,5
3337HA01	∅ 18,0	3,0	8,0	1,2
3338HA01	∅ 18,0	3,0	8,0	1,5
3311HA01	∅ 20,0	3,0	7,0	1,0
3312HA01	∅ 20,0	3,0	7,0	1,2
3313HA01	∅ 20,0	3,0	7,0	1,5
3327HA01	∅ 25,0	4,0	7,0	1,0
3328HA01	∅ 25,0	4,0	7,0	1,2
3329HA01	∅ 25,0	4,0	7,0	1,5
3330HA01	∅ 25,0	4,0	7,0	2,0

P/N	A	B	C	D
3322HA01	∅ 30,0	4,0	10,0	1,0
3323HA01	∅ 30,0	4,0	10,0	1,2
3324HA01	∅ 30,0	4,0	10,0	1,5
3335HA01	∅ 35,0	4,0	11,0	1,2
3336HA01	∅ 35,0	4,0	11,0	1,5
3314HA01	∅ 40,0	4,0	11,0	1,2
3315HA01	∅ 40,0	4,0	11,0	1,5
3325HA01	∅ 45,0	5,0	11,0	1,2
3326HA01	∅ 45,0	5,0	11,0	1,5
3333HA01	∅ 50,0	5,0	11,0	1,2
3334HA01	∅ 50,0	5,0	11,0	1,5
3339HA01	∅ 60,0	5,0	12,0	1,2
3340HA01	∅ 60,0	5,0	12,0	1,5
3316HA01	∅ 80,0	5,0	12,0	1,2
3317HA01	∅ 80,0	5,0	12,0	1,5
3318HA01	∅ 80,0	5,0	12,0	2,0

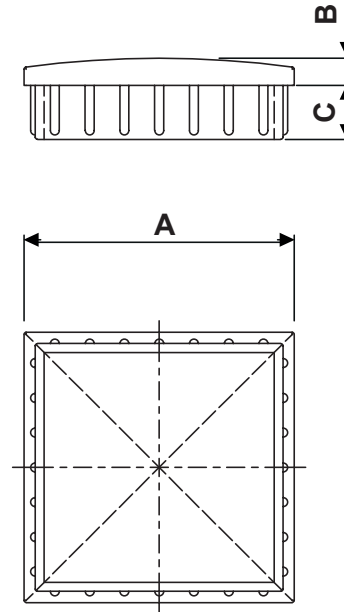

D= PIPE THICKNESS

* COLOUR: CHROMED UPON REQUEST

DESCRIPTION		TITLE: SQUARE TUBE PLUGS		DWG UNIT: MM	
MATERIAL: ABS		Modelled in RHINO 4.0	FILE:	DwN: 06/05/21	ChkD:
COLOUR: BLACK		TOLLERANCES UNLESS NOTED	SHEET: 1 OF 1	DT:21.05.06.3XXX.0.EI	Part Number: SEE TABLE
WORKING TEMPERATURE: -30°C ~ +90°C		SEE ABOVE	SCALE: NTS		
REV.	DATE				