

DIM.	TOL.
5mm DOWN	±0.2
5~20mm	±0.3
20~40mm	±0.4
40~60mm	±0.5
60~100mm	±0.8
100mm UP	±1.0

REVISIONS			
REV	DESCRIPTION	DATE	BY

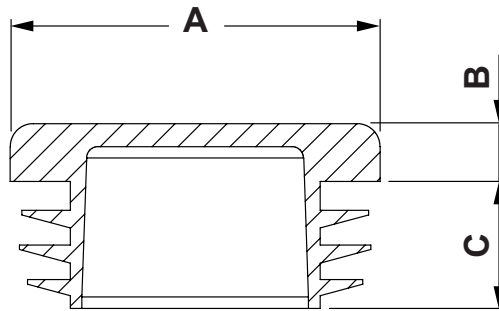

D= PIPE THICKNESS

P/N	A	B	C	D
9501EA01	∅ 12,0	4,0	11,5	1,0-2,0
9502EA01	∅ 13,0	4,0	11,5	1,0-2,0
9503EA01	∅ 15,0	5,0	11,5	1,0-2,0
9504EA01	∅ 16,0	5,0	11,5	1,0-2,5
9505EA01	∅ 18,0	5,0	11,5	1,5-3,0
9506EA01	∅ 20,0	5,0	11,5	1,0-2,25
9507EA01	∅ 22,0	5,0	11,5	1,0-3,5
9508EA01	∅ 25,0	5,0	11,5	1,2-2,25
9509EA01	∅ 28,0	5,0	11,5	2,0-3,0
9510EA01	∅ 30,0	5,0	11,5	1-2-2,25
9511EA01	∅ 30,0	5,0	11,5	2,5-4,5
9512EA01	∅ 32,0	5,0	11,5	1,5-3,5
9513EA01	∅ 35,0	5,0	14,5	1,0-2,5
9514EA01	∅ 35,0	5,0	14,5	3,0-5,0
9515EA01	∅ 40,0	5,0	15,0	1,5-2,5
9516EA01	∅ 40,0	5,0	14,5	3,0-5,0
9517EA01	∅ 45,0	5,0	14,5	1,0-3,0

P/N	A	B	C	D
9518EA01	∅ 50,0	4,2	13,5	1,5-3,0
9519EA01	∅ 50,0	6,5	24,5	2,6-4,0
9520EA01	∅ 50,0	5,0	19,0	2,6-5,0
9521EA01	∅ 50,0	5,0	14,5	3,0-5,0
9522EA01	∅ 55,0	5,0	14,5	2-4,5
9523EA01	∅ 60,0	5,0	18,0	1,5-3,5
9524EA01	∅ 60,0	6,5	17,5	2,6-4,0
9525EA01	∅ 60,0	4,0	15,0	5,0
9526EA01	∅ 65,0	5,0	21,0	2,0-4,0
9527EA01	∅ 70,0	5,0	19,0	2,0-4,5
9528EA01	∅ 70,0	5,0	17,0	5,0
9529EA01	∅ 80,0	6,0	21,0	2,0-4,0
9530EA01	∅ 80,0	8,0	24,0	2,9-5,0
9531EA01	∅ 90,0	6,0	18,0	3,0-5,0
9532EA01	∅ 100,0	7,0	24,0	1,0-4,0
9533EA01	∅ 100,0	5,0	23,0	3,0-6,0

		TITLE SQUARE TUBE PLUGS	
		MATERIAL PE-LD	DATE 26/04/2021
PART NUMBER SEE TABLE		DRAWING NUMBER 21.04.26.95XX.0.E	
DRAWN R.F.		COLOR BLACK	CHECK
SIZE A4	SCALE NTS	UNIT mm.	REV A
UNLESS OTHERWISE SPECIFIED TOLERANCE SEE ABOVE		APPROVED	