

DIM.	TOL.
5mm DOWN.	±0.2
5~20mm	±0.3
20~40mm	±0.4
40~60mm	±0.5
60~100mm	±0.8
100mm UP.	±1.0

REVISIONS			
REV	DESCRIPTION	DATE	BY

FOR P.C.B:Ø3.0
P.C.B THICKNESS:1.2~1.7

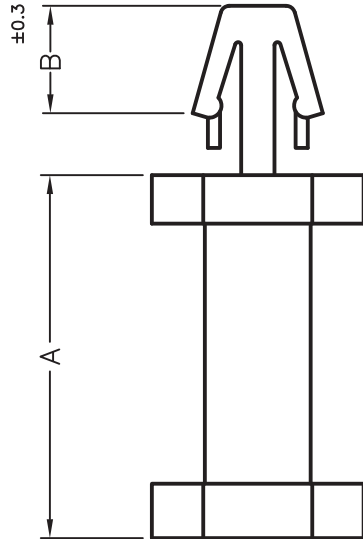

PART NO.	A	B ±0.3
8183AA00	9.0	4.0 ^{±0.3}
8184AA00	11.0	4.0 ^{±0.3}
8185AA00	12.0	3.7 ^{±0.3}

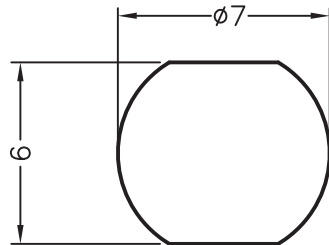

NOTE: All measurement does not include gate which raises under 0.3mm.

				TITLE P.C.B. SUPPORT	
				MATERIAL PA 66 V2 UL 94	DATE 19/07/2013
PART NUMBER SEE TABLE				FINISH	DRAWN D.C.
				DRAWING NUMBER 13.07.19.8183.0.E	
SIZE A4	SCALF NTS	UNIT mm.	REV A	UNLESS OTHERWISE SPECIFIED TOLERANCE SEE ABOVE	
				APPROVED	