

DIM.	TOL
5mm DOWN	±0.2
5~20mm	±0.3
20~40mm	±0.4
40~60mm	±0.5
60~100mm	±0.8
100mm UP	±1.0

REVISIONS			
REV	DESCRIPTION	DATE	BY

HOLE IN P.C.B $\phi 3$
P.C.B THICKNESS 1.2~1.7

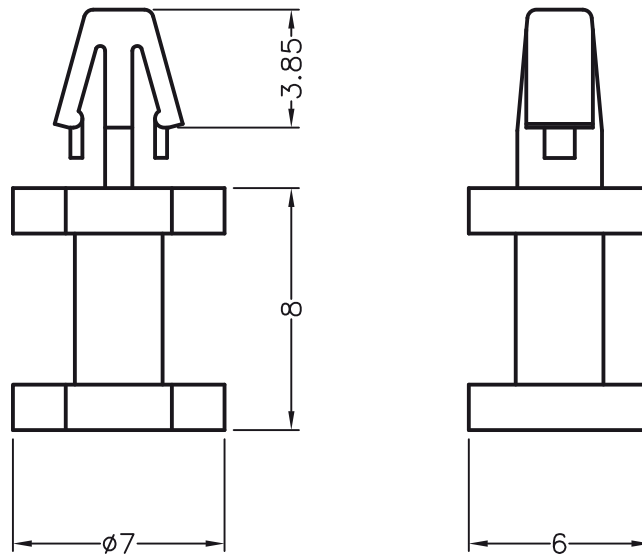

TITLE SPACER SUPPORT		MATERIAL PA 66 V2 UL 94		DATE 17/05/2011	
		FINISH		DRAWN D.C.	
PART NUMBER 8182AA00		DRAWING NUMBER 11.05.17.8182.0.E		COLOR NATURAL	
SIZE A4		SCALE 4:1		CHECK	
UNIT mm.		REV C		UNLESS OTHERWISE SPECIFIED TOLERANCE SEE ABOVE	
				APPROVED	