

Dimensions	Tolerance
5mm DOWN	±0.2
5~20mm	±0.3
20~40mm	±0.4
40~60mm	±0.5
60~100mm	±0.8
100mm UP	±1.0

REVISIONS			
REV	DESCRIPTION	DATE	BY

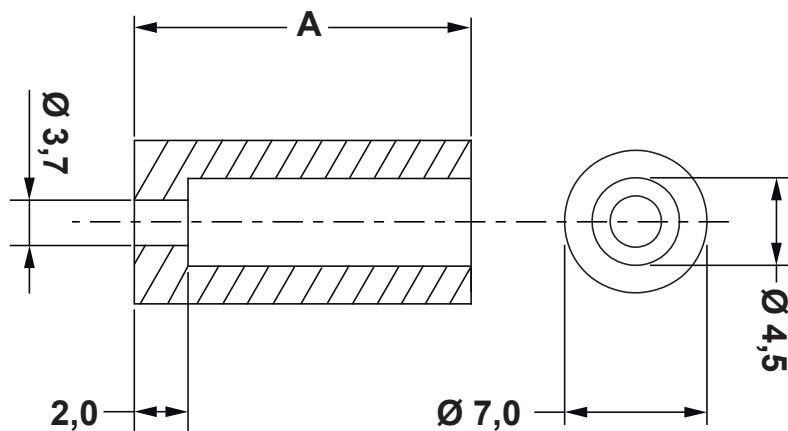

P/N	A
10078BB0102.0	2.0
10078BB0103.0	3.0
10078BB0104.0	4.0
10078BB0105.0	5.0
10078BB0106.0	6.0
10078BB0107.0	7.0
10078BB0108.0	8.0
10078BB0109.0	9.0
10078BB0110.0	10.0
10078BB0111.0	11.0
10078BB0112.0	12.0
10078BB0113.0	13.0
10078BB0114.0	14.0
10078BB0115.0	15.0
10078BB0116.0	16.0
10078BB0117.0	17.0
10078BB0118.0	18.0
10078BB0119.0	19.0
10078BB0120.0	20.0
10078BB0121.0	21.0

P/N	A
10078BB0122.0	22.0
10078BB0123.0	23.0
10078BB0124.0	24.0
10078BB0125.0	25.0
10078BB0126.0	26.0
10078BB0127.0	27.0
10078BB0128.0	28.0
10078BB0129.0	29.0
10078BB0130.0	30.0
10078BB0131.0	31.0
10078BB0132.0	32.0
10078BB0133.0	33.0
10078BB0134.0	34.0
10078BB0135.0	35.0
10078BB0136.0	36.0
10078BB0137.0	37.0
10078BB0138.0	38.0
10078BB0139.0	39.0
10078BB0140.0	40.0
10078BB0141.0	41.0

P/N	A
10078BB0142.0	42.0
10078BB0143.0	43.0
10078BB0144.0	44.0
10078BB0145.0	45.0
10078BB0146.0	46.0
10078BB0147.0	47.0
10078BB0148.0	48.0
10078BB0149.0	49.0
10078BB0150.0	50.0

		TITLE ROUND SPACERS	
		MATERIAL PA 6 25%GV HB(UL94)	DATE 15/04/2021
PART NUMBER SEE TABLE		DRAWING NUMBER 21.04.15.10078.0.E	
DRAWN R.F.		COLOR BLACK	CHECK
SIZE A4	SCALE NTS	UNIT mm.	REV A
UNLESS OTHERWISE SPECIFIED TOLERANCE SEE ABOVE		APPROVED	