

REVISIONS			
REV	DESCRIPTION	DATE	BY

**Standard Sealing**

**IP 68**  
with O-Ring  
OPTIONAL

**Permanent temperature on application**

**NITRILE**  
- 25 / + 120°C

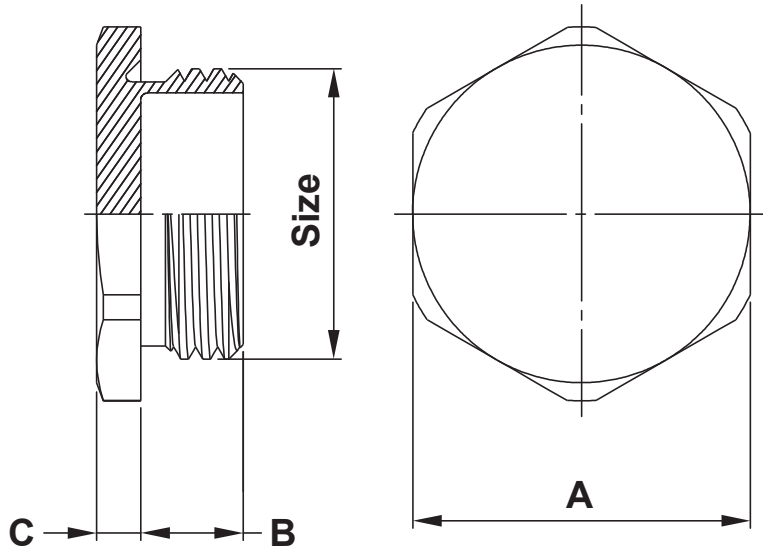

P/N	Size	A	B	C
15229MD90	PG 09	17,0	6,0	3,0
15230MD90	PG 11	19,0	6,0	3,0
15231MD90	PG 13	21,0	6,5	3,0
15232MD90	PG 16	23,0	6,5	3,0
15233MD90	PG 21	29,0	7,0	4,0
15234MD90	PG 29	39,0	8,0	4,0

		TITLE <b>PG HEXAGONAL PLUGS STAINLESS STEEL</b>	
		MATERIAL STAINLESS STEEL	DATE 26/02/2021
PART NUMBER SEE TABLE		DRAWING NUMBER 21.02.26.1522X.0.E	
DRAWN R.F.		COLOR SEE ABOVE	CHECK
SIZE A4	SCALE NTS	UNIT mm.	REV A
UNLESS OTHERWISE SPECIFIED TOLERANCE SEE ABOVE		APPROVED	