

DIM.	TOL
L ≤ 10	±0.2
10 < L ≤ 30	±0.3
30 < L ≤ 50	±0.5
50 < L ≤ 100	±0.7
100 < L ≤ 250	±1.2
ABOVE 250	±1.5

REVISIONS			
REV	DESCRIPTION	DATE	BY

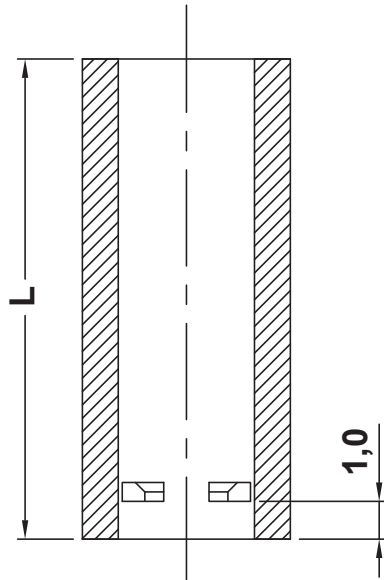

SECTION A-A

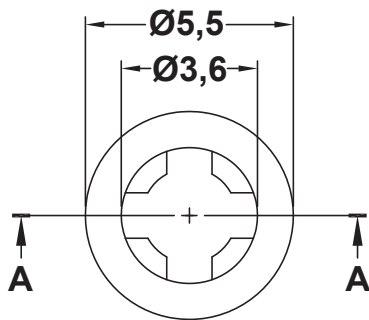

PART NO.	L
11454AA0001.5	1,5
11454AA0002.0	2,0
11454AA0003.0	3,0
11454AA0003.5	3,5
11454AA0004.0	4,0
11454AA0005.0	5,0
11454AA0006.0	6,0
11454AA0006.3	6,3
11454AA0007.0	7,0
11454AA0008.0	8,0
11454AA0009.0	9,0
11454AA0009.5	9,5
11454AA0010.0	10,0
11454AA0011.0	11,0
11454AA0011.5	11,5
11454AA0012.0	12,0
11454AA0012.7	12,7
11454AA0013.0	13,0
11454AA0014.0	14,0

PART NO.	L
11454AA0015.0	15,0
11454AA0015.9	15,9
11454AA0016.0	16,0
11454AA0017.0	17,0
11454AA0018.0	18,0
11454AA0019.0	19,0
11454AA0020.0	20,0
11454AA0021.0	21,0
11454AA0022.0	22,0
11454AA0023.0	23,0
11454AA0024.0	24,0
11454AA0025.0	25,0
11454AA0025.4	25,4
11454AA0026.0	26,0
11454AA0027.0	27,0
11454AA0028.0	28,0
11454AA0029.0	29,0
11454AA0030.0	30,0



		TITLE SPACER SUPPORT			
		MATERIAL PA66 V2 (UL94)	DATE 03/10/2017		
		COLOR NATURAL	DRAWN R.F.		
PART NUMBER SEE TABLE	DRAWING NUMBER 17.10.03.11454.0.E	CHECK			
SIZE A4	SCALE NTS	UNIT mm	REV A	UNLESS OTHERWISE SPECIFIED TOLERANCE SEE ABOVE	APPROVED