

DIM	TOL
5mm DOWN	±0.2
5~20mm	±0.3
20~40mm	±0.4
40~60mm	±0.5
60~100mm	±0.8
100mm UP	±1.0

REVISIONS			
REV	DESCRIPTION	DATE	BY

**HOLE IN P.C.B Ø2,0  
P.C.B THICKNESS 1,6mm**

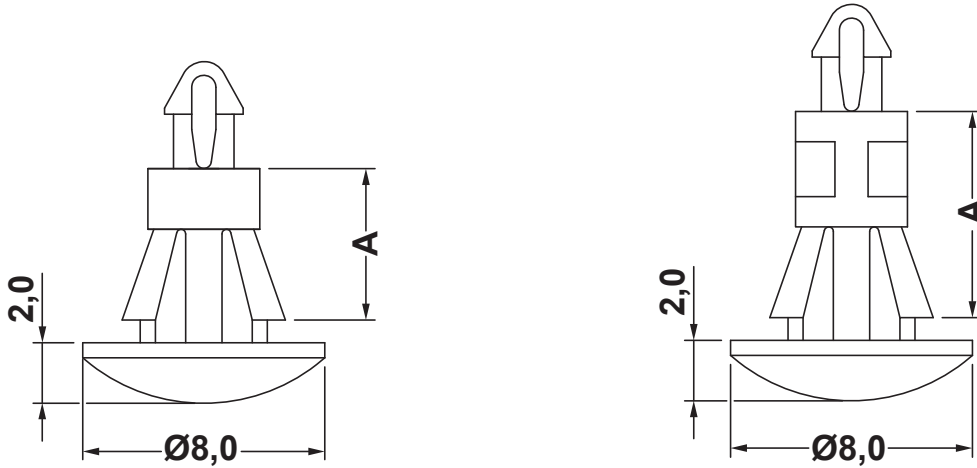

**HOLE IN CHASSIS Ø4,0  
CHASSIS THICKNESS 0,8-1,6mm**

PART NO.	A
11408AA0003,2	3.2
11408AA0004,0	4.0
11408AA0004,5	4.5
11408AA0005,0	5.0
11408AA0005,5	5.5

PART NO.	A
11408AA0006,0	6.0
11408AA0006,4	6.4
11408AA0007,0	7.0
11408AA0007,5	7.5
11408AA0008,0	8.0
11408AA0009,0	9.0
11408AA0009,5	9.5
11408AA0010,0	10.0
11408AA0011,1	11.1
11408AA0012,0	12.0
11408AA0012,7	12.7
11408AA0014,0	14.0
11408AA0016,0	16.0

				TITLE <b>SPACER SUPPORT</b>	
				MATERIAL PA66 V2(UL94)	DATE 21/03/2018
PART NUMBER SEE TABLE				DRAWN R.F.	
				DRAWING NUMBER 18.03.21.11408.0.E	
SIZE A4				COLOR NATURAL	
				CHECK	
SCALE NTS		UNIT mm.		REV A	
UNLESS OTHERWISE SPECIFIED TOLERANCE SEE ABOVE				APPROVED	