

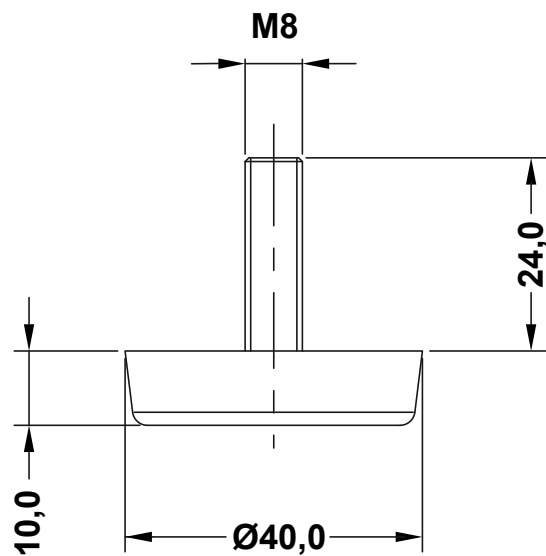

Dimensions	Tolerance
5mm DOWN	±0.2
5~20mm	±0.3
20~40mm	±0.4
40~60mm	±0.5
60~100mm	±0.8
100mm UP	±1.0

REVISIONS			
REV	DESCRIPTION	DATE	BY



NOTES:
FEET MATERIAL: TPE
SCREW MATERIAL: ZINC PLATED IRON

				TITLE ADJUSTMENT FOOT WITH FLAT BASE	
				MATERIAL SEE ABOVE	
PART NUMBER 13249GS01				DRAWING NUMBER 20.07.14.13249.0.E	
COLOR BLACK				CHECK	
UNLESS OTHERWISE SPECIFIED TOLERANCE SEE ABOVE				APPROVED	
SIZE A4	SCALE NTS	UNIT mm.	REV A		