

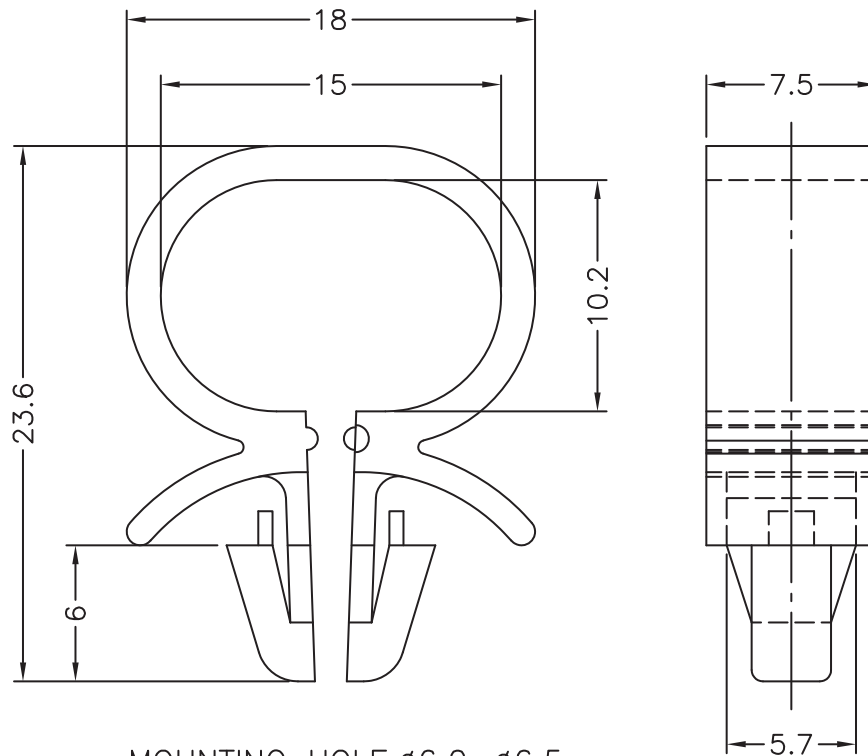

| DIM. | TOL |
|----------|------|
| 5mm DOWN | ±0.2 |
| 5~20mm | ±0.3 |
| 20~40mm | ±0.4 |
| 40~60mm | ±0.5 |
| 60~100mm | ±0.8 |
| 100mm UP | ±1.0 |

| REVISIONS | | | |
|-----------|-------------|------|----|
| REV | DESCRIPTION | DATE | BY |
| | | | |
| | | | |



MOUNTING HOLE: $\phi 6.0 \sim \phi 6.5$
 CHASSIS THICKNESS: $0.8 \sim 2.5$

- NOTE: 1. Shrinking is normal status.
 2. All measurement does not include gate which raises under 0.3mm.

| | | | | | |
|--|--|--|--|--|--------------------|
|  | | | | TITLE OPEN ANCHOR WIRE CLIP | |
| | | | | MATERIAL PA66 V2 UL94 | DATE 25/03/2013 |
| PART NUMBER 6524AA00 | | | | DRAWING NUMBER 13.03.25.6524.0.E | |
| | | | | FINISH | DRAWN D.C. |
| SIZE A4 | | | | COLOR NATURAL | |
| | | | | SCALE 3:1 | CHECK |
| UNIT mm. | | | | UNLESS OTHERWISE SPECIFIED TOLERANCE SEE ABOVE | |
| | | | | APPROVED | |
| REV B | | | | | |
| | | | | | |