

DIM.	TOL.
5mm DOWN	±0.2
5~20mm	±0.3
20~40mm	±0.4
40~60mm	±0.5
60~100mm	±0.8
100mm UP	±1.0

REVISIONS			
REV	DESCRIPTION	DATE	BY

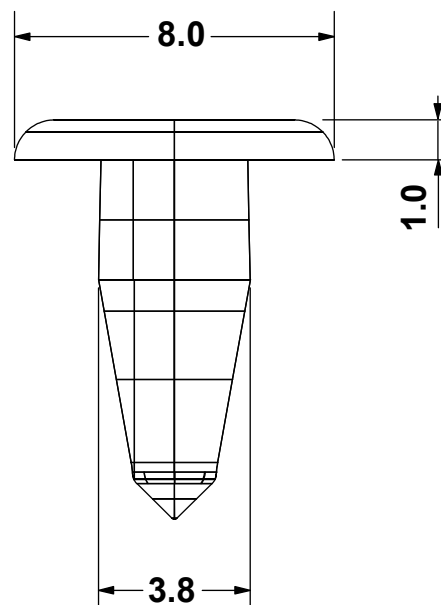

**MOUNTING HOLE Ø4,5
THICKNESS: 3,0**

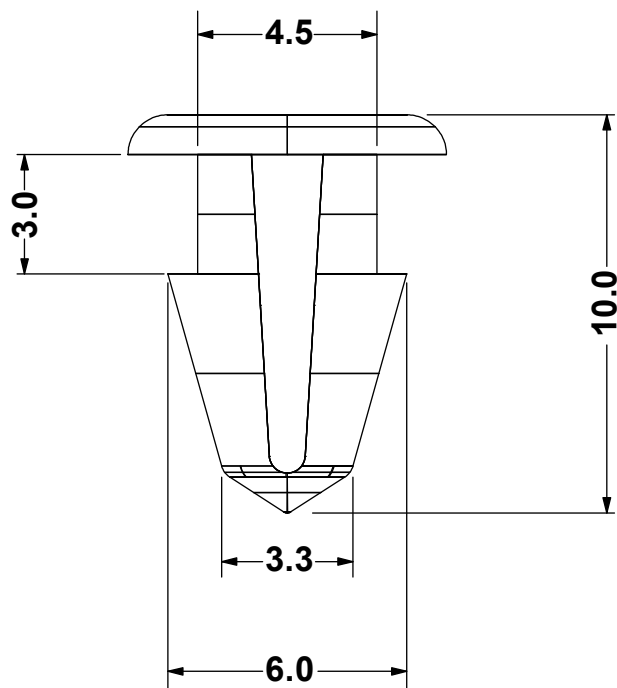
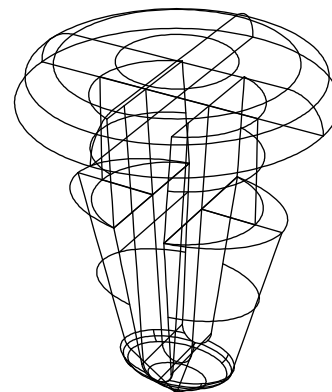
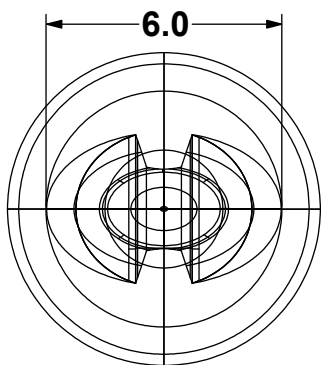

TITLE
CLIPS

MATERIAL
PA 6.6 V2(UL94)

DATE
25/07/2018

DRAWN
R.F.

COLOR
BLACK

CHECK

UNLESS OTHERWISE SPECIFIED
TOLERANCE
SEE ABOVE

APPROVED

PART NUMBER
5323AA01

DRAWING NUMBER
18.07.25.5323.0.E

SIZE
A4

SCALE
NTS

UNIT
mm.

REV
A