

REVISIONS			
REV	DESCRIPTION	DATE	BY

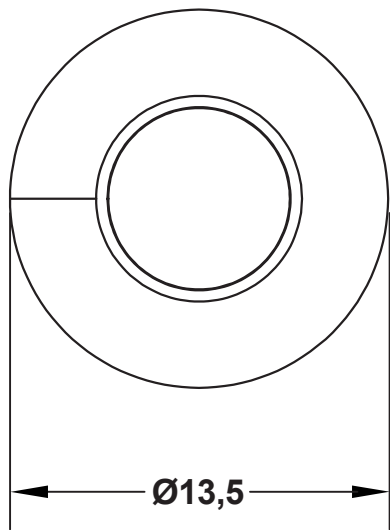
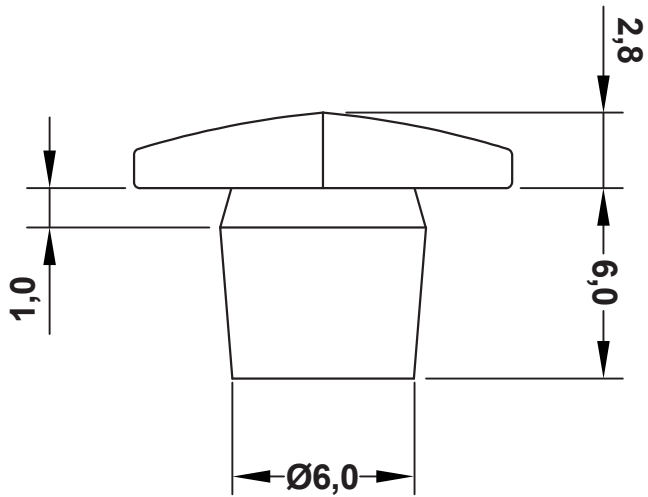
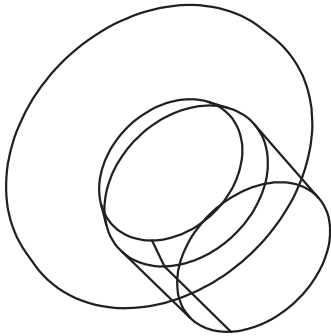

TITLE **FEETS & PUSH-IN BUMPERS**

MATERIAL TPE	DATE 29/11/2018
-----------------	--------------------

	DRAWN R.F.
--	---------------

COLOR BLACK	CHECK
----------------	-------

PART NUMBER 4808PS01	DRAWING NUMBER 18.11.29.4808.0.E
-------------------------	-------------------------------------

UNLESS OTHERWISE SPECIFIED TOLERANCE	APPROVED
--------------------------------------	----------

SIZE A4	SCALE NTS	UNIT mm.	REV A
------------	--------------	-------------	----------