

| DIM. | TOL. |
|----------|------|
| 5mm DOWN | ±0.2 |
| 5~20mm | ±0.3 |
| 20~40mm | ±0.4 |
| 40~60mm | ±0.5 |
| 60 100mm | ±0.8 |
| 100mm UP | ±1.0 |

| REVISIONS | | | |
|-----------|-------------|------|----|
| REV | DESCRIPTION | DATE | BY |
| | | | |
| | | | |
| | | | |

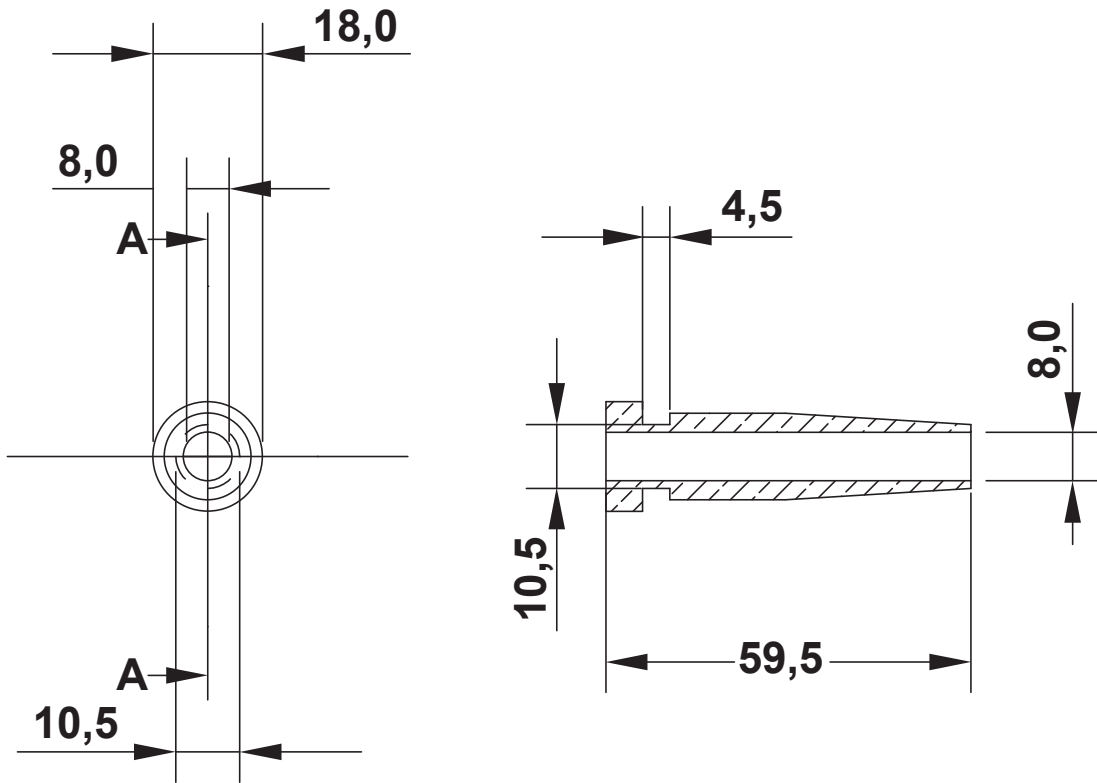

TITLE SOFT SPECIAL CABLE GROMMETS

MATERIAL PVC HB (UL94)

DATE 30/08/2017

COLOR BLACK

DRAWN R.F.

PART NUMBER 3463CA01

DRAWING NUMBER 17.08.30.3463.0.E

CHECK

SIZE A4

SCALE NTS

UNIT mm

REV A

UNLESS OTHERWISE SPECIFIED TOLERANCE SEE ABOVE

APPROVED