

DIM.	TOL.
5mm DOWN	±0.2
5~20mm	±0.3
20~40mm	±0.4
40~60mm	±0.5
60 100mm	±0.8
100mm UP	±1.0

REVISIONS			
REV	DESCRIPTION	DATE	BY

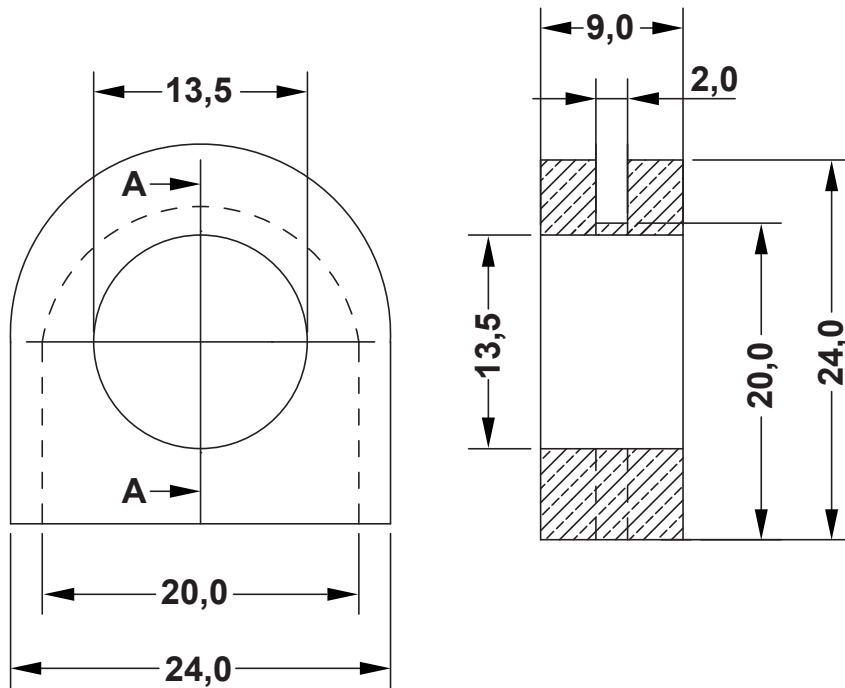

NOTES: WITH MEMBRANE



fastpoint		TITLE SOFT BORDER GROMMETS			
		MATERIAL PVC HB(UL94)	DATE 31/08/2017		
		COLOR BLACK	DRAWN R.F.		
PART NUMBER 13081CA01M	DRAWING NUMBER 17.08.31.13081.0.E	CHECK			
SIZE A4	SCALE NTS	UNIT mm	REV A	UNLESS OTHERWISE SPECIFIED TOLERANCE SEE ABOVE	APPROVED