

DIM.	TOL.
5mm DOWN	±0.2
5~20mm	±0.3
20~40mm	±0.4
40~60mm	±0.5
60~100mm	±0.8
100mm UP	±1.0

REVISIONS			
REV	DESCRIPTION	DATE	BY

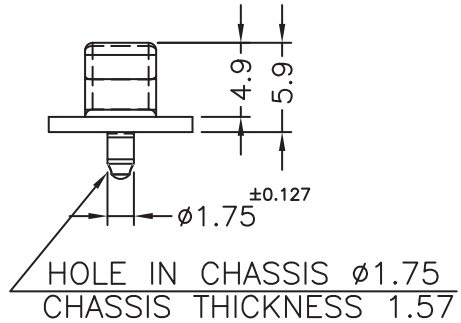
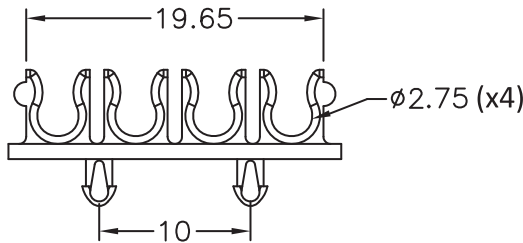
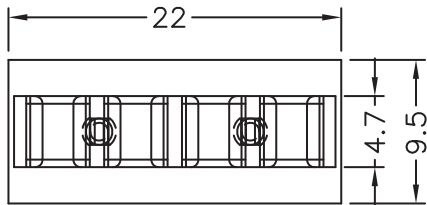
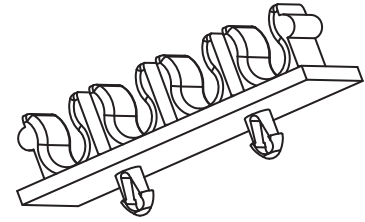

fastpoint		TITLE		WIRE MOUNT	
		MATERIAL		DATE	
		ADESIVO		DRAWN	
PART NUMBER		DRAWING NUMBER		COLOR	
11349AA00		16.09.02.11349.0.E		NATURAL	
SIZE		UNIT		UNLESS OTHERWISE SPECIFIED TOLERANCE	
A4		mm		SEE ABOVE	
SCALE		REV		APPROVED	
2:1		A			