

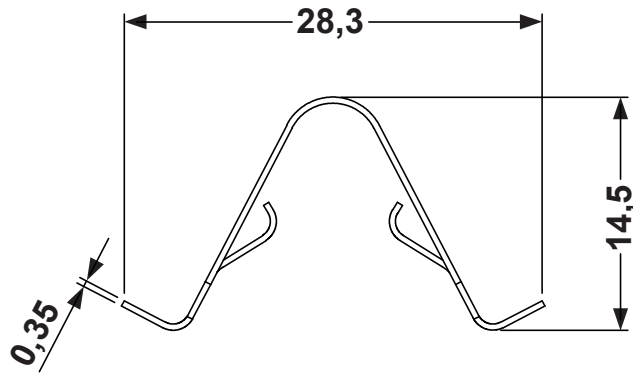

REVISIONS			
REV	DESCRIPTION	DATE	BY

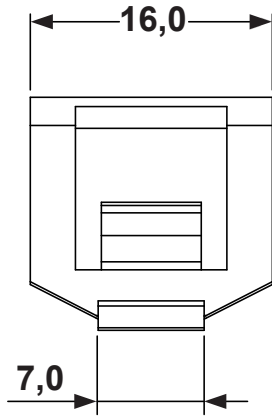

APPLICATION

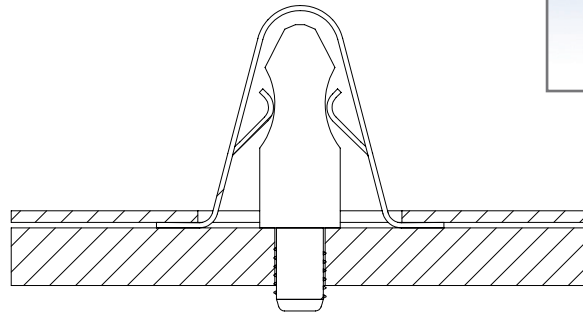
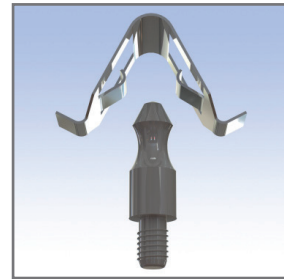

NOTES:
Suggested template: 8,0 x 13,0 mm
Thickness: 0,8 - 1,2 mm
Please slightly reduce the template for higher load

				TITLE METAL STRIKES AND LATCHES	
				MATERIAL SPRING STEEL	DATE 19/07/2017
PART NUMBER 0970MC90				DRAWN R.F.	
DRAWING NUMBER 17.07.19.0970.0.E				CHECK	
SIZE A4	SCALE NTS	UNIT mm.	REV A	UNLESS OTHERWISE SPECIFIED TOLERANCE SEE ABOVE	
				APPROVED	