

DIM.	TOL.
5mm DOWN	±0.2
5~20mm	±0.3
20~40mm	±0.4
40~60mm	±0.5
60~100mm	±0.8
100mm UP	±1.0

REVISIONS			
REV	DESCRIPTION	DATE	BY

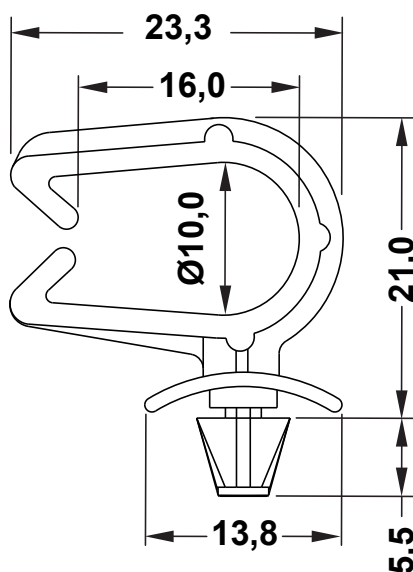

THICKNESS: 0,6 - 1,7
MOUNTING HOLE: Ø5,0

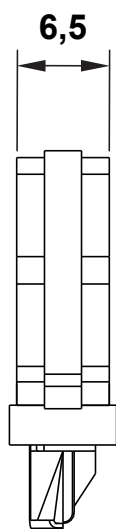
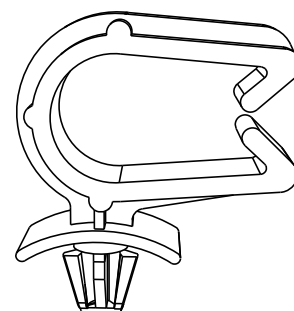

TITLE WIRE CLIPS – SIDE OPENING HOLE Ø 5,0 MM.		MATERIAL PA66 V2(UL94)		DATE 27/09/2021	
		COLOR NATURAL		DRAWN R.F.	
PART NUMBER 0021AA00		DRAWING NUMBER 21.09.27.0021.0.E		CHECK APPROVED	
SIZE A4	SCALE NTS	UNIT mm.	REV A	UNLESS OTHERWISE SPECIFIED TOLERANCE SEE ABOVE	