

REVISIONS

REV	DESCRIPTION	DATE	BY

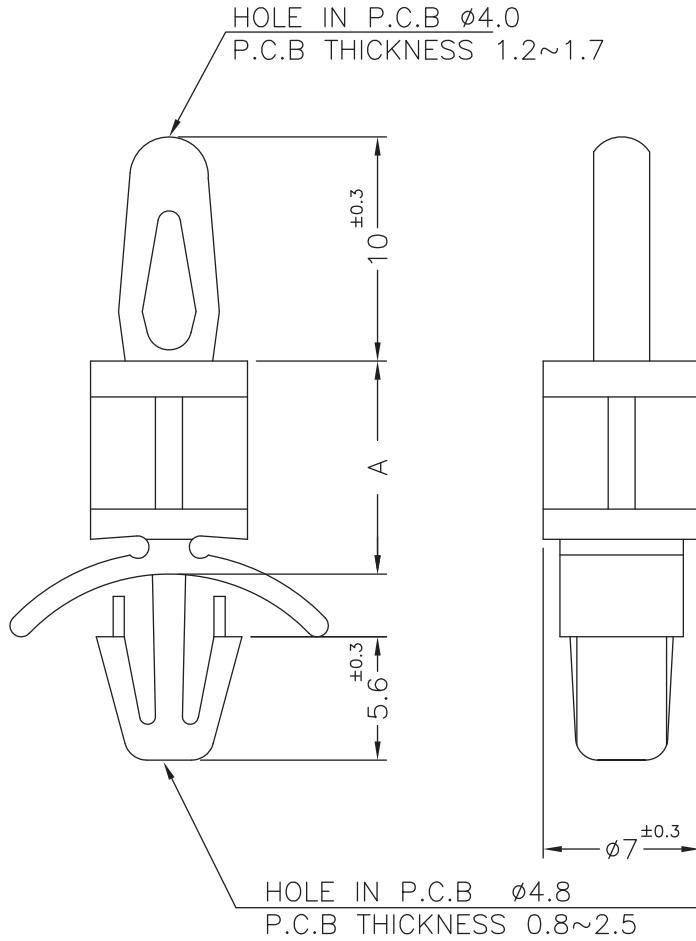

PART NO.	A
8353AA0007.90	7,9 ^{±0.3}
8353AA0009.50	9,5 ^{±0.3}
8353AA0012.70	12,7 ^{±0.3}
8253AA0022.20	22,2 ^{±0.4}



<p>TITLE</p> <p style="text-align: center;">SPACER SUPPORT</p>					
		<p>MATERIAL</p> <p style="text-align: center;">NYLON 66 UL94V-2</p>	<p>DATE</p> <p style="text-align: center;">15/09/2015</p>		
		<p>HARDNESS</p>	<p>DRAWN</p> <p style="text-align: center;">S.P.</p>		
<p>PART NUMBER</p> <p style="text-align: center;">SEE ABOVE</p>	<p>DRAWING NUMBER</p> <p style="text-align: center;">15.09.15.8353.0.E</p>	<p>COLOR</p> <p style="text-align: center;">NATURAL</p>	<p>CHECK</p>		
<p>SIZE</p> <p style="text-align: center;">A4</p>	<p>SCALE</p> <p style="text-align: center;">NTS</p>	<p>UNIT</p> <p style="text-align: center;">mm</p>	<p>REV</p> <p style="text-align: center;">A</p>	<p>UNLESS OTHERWISE SPECIFIED TOLERANCE</p> <p style="text-align: center;">SEE ABOVE</p>	<p>APPROVED</p>