

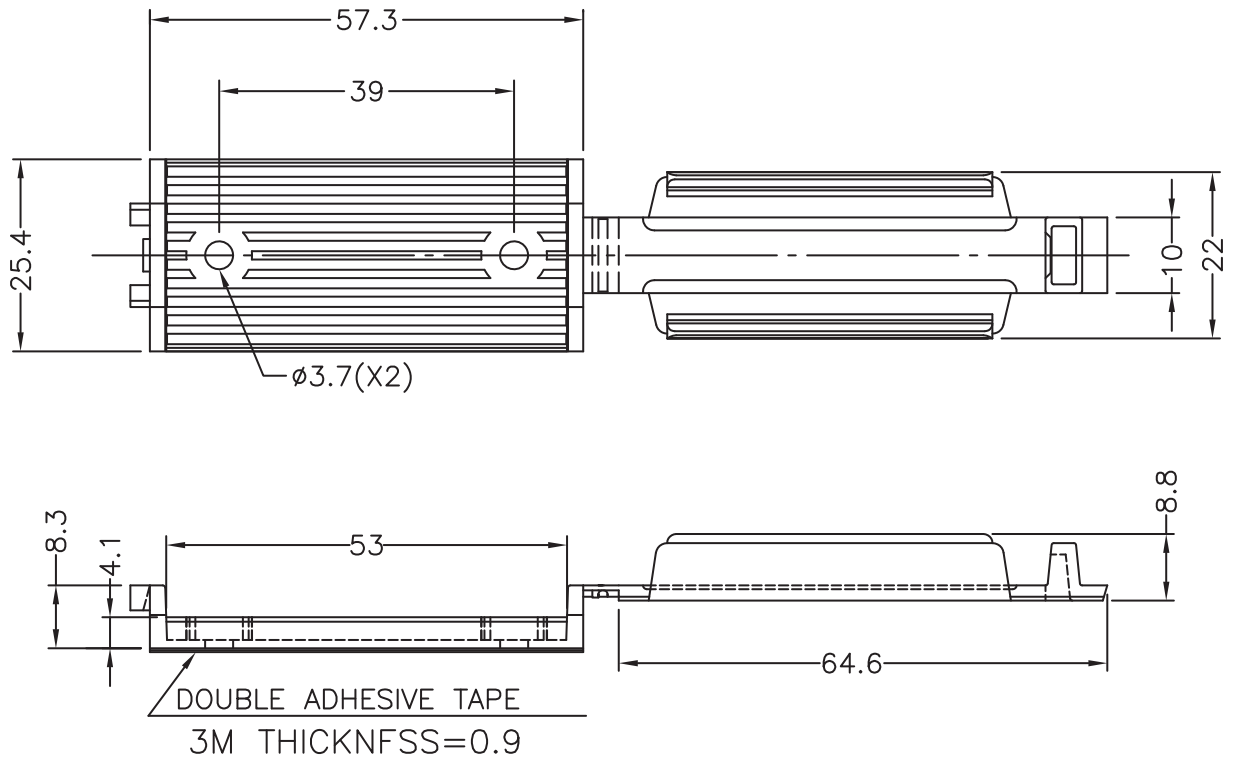

DIM.	TOL
5mm DOWN	±0.2
5~20mm	±0.3
20~40mm	±0.4
40~60mm	±0.5
60~100mm	±0.8
100mm UP	±1.0

REVISIONS			
REV	DESCRIPTION	DATE	BY



- NOTE: 1. All measurement does not include gate which raises under 0.3mm.
 2. The Height is not include the releasing paper and adhesive tape's thickness.
 3. The adhesive tape is cut by hand , it is normal if there is a not unified edge.

				TITLE WIRE CLIP - SIDE OPENING	
				MATERIAL PA66 V2 UL94	DATE 17/06/2015
PART NUMBER 6383AA11AS				DRAWING NUMBER 11.05.17.6383.0.E	
				COLOR GREY	
SIZE A4	SCALE 1:1	UNIT mm.	REV C	UNLESS OTHERWISE SPECIFIED TOLERANCE	
				APPROVED	