

DIM.	TOL.
5mm DOWN	±0.2
5~20mm	±0.3
20~40mm	±0.4
40~60mm	±0.5
60~100mm	±0.8
100mm UP	±1.0

REVISIONS			
REV	DESCRIPTION	DATE	BY

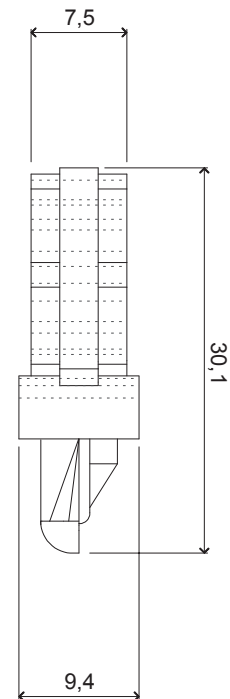

PANEL HOLE: Ø 6,5
THICKNESS: 0,8 - 2,0

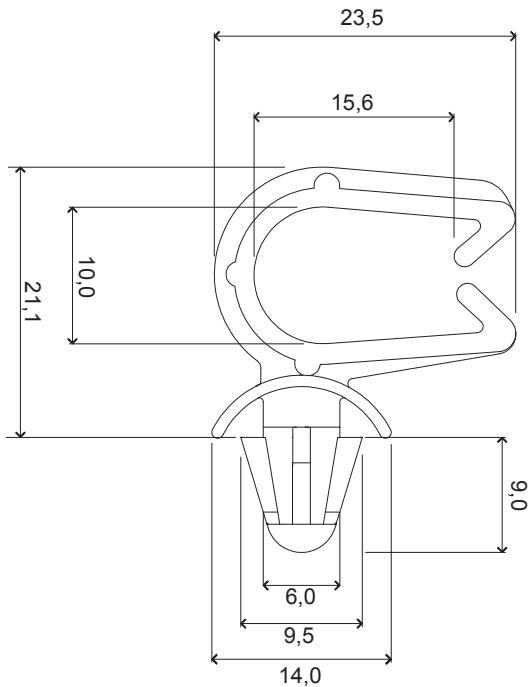
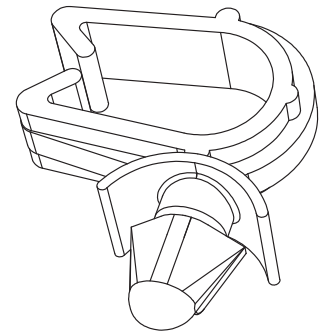

TITLE WIRE CLIP - SIDE OPENING		MATERIAL PA 66 V2 UL94		DATE 15/09/2015	
		HARDNESS		DRAWN S.P.	
		COLOR BLACK		CHECK	
PART NUMBER 5767AA01		DRAWING NUMBER 15.09.15.5767.0.E		UNLESS OTHERWISE SPECIFIED TOLERANCE SEE ABOVE	
SIZE A4	SCALE NTS	UNIT mm	REV A	APPROVED	