

DIM.	TOL.
L < 5	±0.2
5 < L < 20	±0.3
20 < L < 40	±0.5
40 < L < 60	±0.7
60 < L < 100	±0.8
ABOVE 100	±1.0

REVISIONS			
REV	DESCRIPTION	DATE	BY

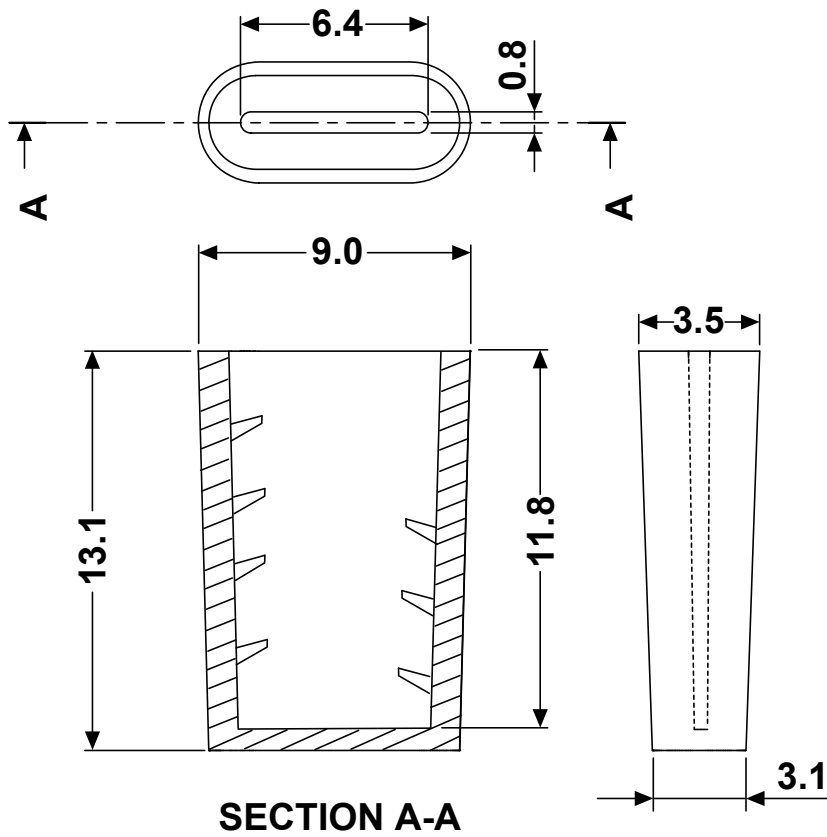

SECTION A-A

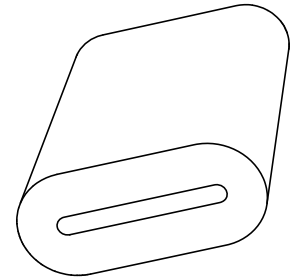

TITLE CAPS FOR TAB

MATERIAL	PVC	DATE	28/08/2017
FINISH		DRAWN	R.F.
COLOR	BLACK	CHECK	
UNLESS OTHERWISE SPECIFIED TOLERANCE	SEE ABOVE	APPROVED	

PART NUMBER		DRAWING NUMBER	
4441CA01		17.08.28.4441.E.0	
SIZE	SCALE	UNIT	REV
A4	NONE	mm	A