

| REVISIONS | | | |
|-----------|-------------|------|----|
| REV | DESCRIPTION | DATE | BY |
| | | | |
| | | | |

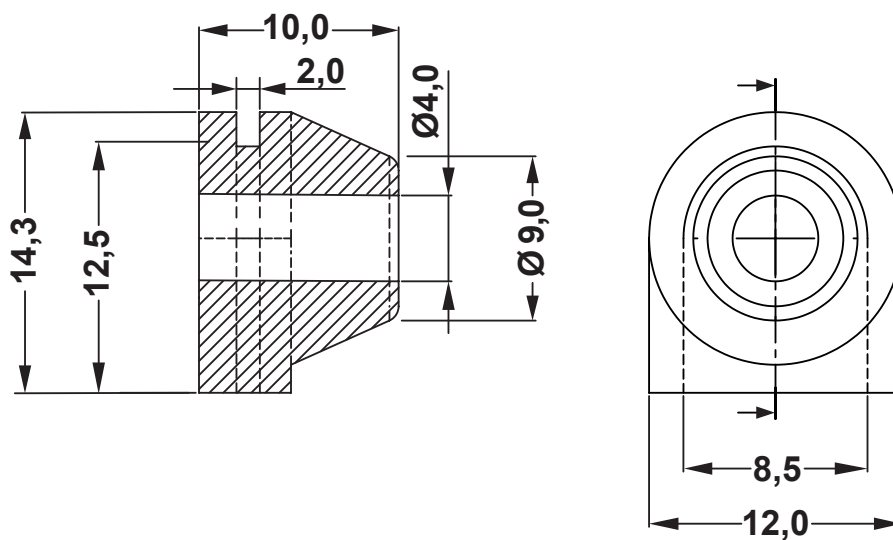

| | | | | | | |
|------------------|-------|-------------------|-----|--------------------------------------|-------|------------|
| fastpoint | | TITLE | | EDGE GROMMET | | |
| | | MATERIAL | | PVC | DATE | 16/12/2013 |
| | | FINISH | | | DRAWN | V.P. |
| | | COLOR | | BLACK | CHECK | |
| PART NUMBER | | DRAWING NUMBER | | | | |
| 4279CA01 | | 13.08.07.4279.E.0 | | | | |
| SIZE | SCALE | UNIT | REV | UNLESS OTHERWISE SPECIFIED TOLERANCE | | |
| A4 | NTS | mm | | DIN ISO 3302-1 M2 | | |
| | | | | APPROVED | | |