

DIM.	TOL.
5mm DOWN	±0.2
5~20mm	±0.3
20~40mm	±0.4
40~60mm	±0.5
60 100mm	±0.8
100mm UP	±1.0

REVISIONS			
REV	DESCRIPTION	DATE	BY

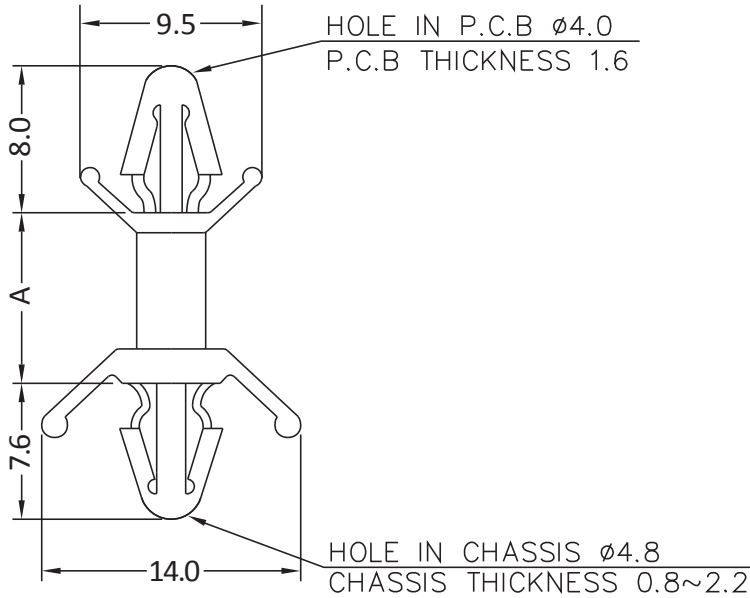

P/N	A
2451AA00	4.6
2452AA00	6.2
2453AA00	9.2
2454AA00	12.6
2455AA00	15.9
2456AA00	19.1
2457AA00	22.1
2458AA00	25.3
2459AA00	28.6

Component - Plastics

E41938

E I DUPONT DE NEMOURS & CO INC
 ENGINEERING POLYMERS, CHESTNUT RUN PLAZA, PO BOX 80713, WILMINGTON DE 19880
101(r9)(f1), 101F(r9)(f1), 101L(r9)(f1), E101(r9)(f1), E101L(r9)(f1)
 Polyamide 66 (PA66), "Zytel", furnished as pellets

Color	Min Thk (mm)	Flame Class	HWI	HAI	RTI Elec	RTI Imp	RTI Str
ALL	0.71	V-2	4	0	130	75	85
	1.5	V-2	3	0	130	75	85
	3.0	V-2	2	0	130	75	85
	6.0	V-2	2	0	130	75	85

Comparative Tracking Index (CTI): 0
 Dielectric Strength (kV/mm): 13
 High-Voltage Arc Tracking Rate (HVTR): 0
 Dimensional Stability (%): -

Inclined Plane Tracking (IPT): -
 Volume Resistivity (10¹⁴ ohm-cm): 14
 High Volt, Low Current Arc Resis (D495): 6

(f1) - Suitable for outdoor use with respect to exposure to Ultraviolet Light, Water Exposure and Immersion in accordance with UL 746C.

NOTE - (1) Material designations that are color pigmented may be followed by suffix letters and numbers. (2) Material designations may be prefixed by "ZYT" for Zytel or "MIN" for Minlon or "DEL" for Delrin or "CRA" for Crastin or "RYN" for Rynite or "ETPV" for ETPV grades.

r9 - Virgin and regrind up to 50% by weight inclusive, have the same basic material characteristics for ALL colors down to 0.71mm. For thickness 0.40mm to 0.70mm the same basic material characteristics exist with the exception of generic RTIs for all properties and Regrind exceeding 25% is limited to V-2 Flammability for WT, RD, BK.

ANSI/UL 94 small-scale test data does not pertain to building materials, furnishings and related contents. ANSI/UL 94 small-scale test data is intended solely for determining the flammability of plastic materials used in the components and parts of end-product devices and appliances, where the acceptability of the combination is determined by UL.

Report Date: 1996-07-29
 Last Revised: 2010-07-27

© 2011 Underwriters Laboratories Inc.



				TITLE SPACER SUPPORT	
				MATERIAL PA66 V2 (UL94)	DATE 21/08/2017
				COLOR NATURAL	DRAWN R.F.
PART NUMBER SEE TABLE		DRAWING NUMBER 17.08.21.245X.0.E		CHECK	
SIZE A4	SCALE NONE	UNIT mm	REV B	UNLESS OTHERWISE SPECIFIED TOLERANCE SEE ABOVE	APPROVED