

DIM.	TOL.
5mm DOWN	±0.2
5~20mm	±0.3
20~40mm	±0.4
40~60mm	±0.5
60~100mm	±0.8
100mm UP	±1.0

REVISIONS			
REV	DESCRIPTION	DATE	BY

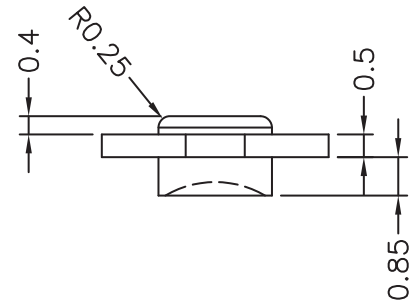
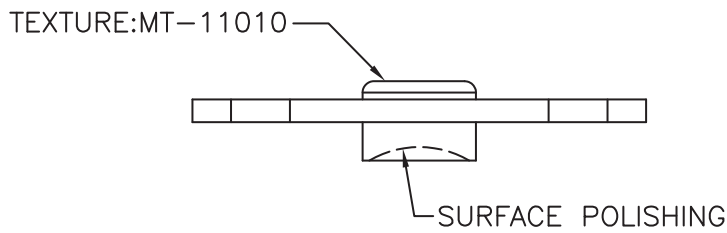
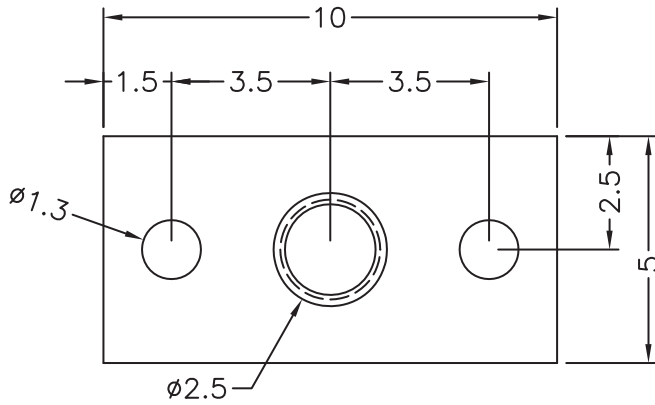

fastpoint		TITLE		LIGHT PIPE	
		MATERIAL	PMMA	DATE	11/05/2016
PART NUMBER		DRAWING NUMBER		DRAWN	
14006PM00		16.05.11.1400.0.E		R.F.	
SIZE		UNIT		CHECK	
A4		mm			
SCALE		REV		UNLESS OTHERWISE SPECIFIED TOLERANCE	
6:1		A		SEE ABOVE	
				APPROVED	