

DIM.	TOL.
5mm DOWN	±0.2
5~20mm	±0.3
20~40mm	±0.4
40~60mm	±0.5
60~100mm	±0.8
100mm UP	±1.0

REVISIONS			
REV	DESCRIPTION	DATE	BY

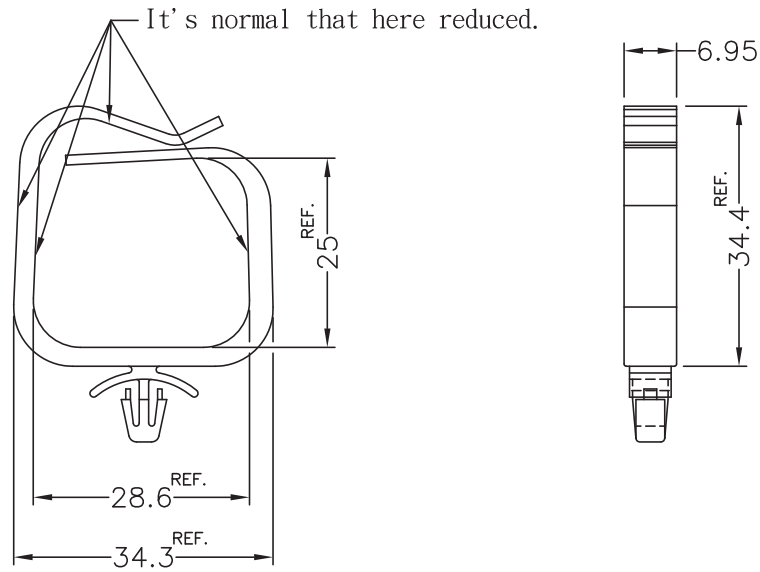

HOLE IN CHASSIS: $\phi 4.8$
 CHASSIS THICKNESS: 0.8~2.0

NOTE:

1. All measurement does not include gate which raises under 0.3 mm.
2. Shrinking is normal status.



		TITLE HARNES CLIP STANDOFF	
		MATERIAL NYLON 66 UL94V-2	DATE 15/09/2015
		DRAWN S.P.	
PART NUMBER 10979AA00		DRAWING NUMBER 15.09.15.10979.0.E	
SIZE A4		SCALE 1:1	
UNIT mm		REV A	
COLOR NATURAL		CHECK	
UNLESS OTHERWISE SPECIFIED TOLERANCE SEE ABOVE		APPROVED	